

# OPERATOR'S MANUAL

## DRYWALL SCREWDRIVER

VARIABLE SPEED/REVERSIBLE  
DOUBLE INSULATED

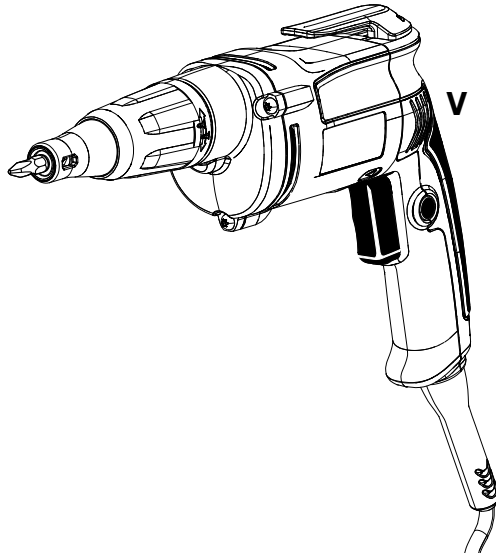

R6000-1

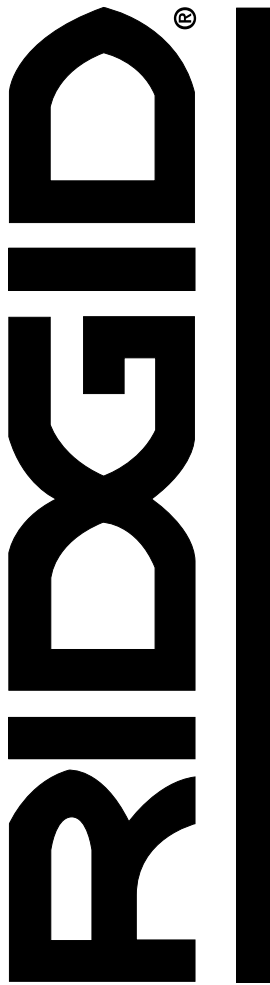

This screwdriver has been engineered and manufactured to our high standard for dependability, ease of operation and operator safety. When properly cared for, the drill will give you years of rugged, trouble-free performance.

### **⚠ WARNING**

To reduce the risk of injury, the user must read and understand the operator's manual before using this product.

Thank you for buying a RIDGID® product.

## SAVE THIS MANUAL FOR FUTURE REFERENCE

Cet tournevis a été conçu et fabriqué conformément à nos strictes normes de fiabilité, simplicité d'emploi et sécurité d'utilisation. Correctement entretenu, il vous donnera des années de fonctionnement robuste et sans problème.

### **⚠ AVERTISSEMENT**

Pour réduire les risques de blessures, l'utilisateur doit lire et veiller à bien comprendre le manuel d'utilisation avant d'utiliser ce produit.

Merci d'avoir acheté un produit RIDGID®.

**CONSERVER CE MANUEL POUR  
FUTURE RÉFÉRENCE**

Su destornillador para paneles de yeso ha sido diseñado y fabricado de conformidad con nuestras estrictas normas para brindar fiabilidad, facilidad de uso y seguridad para el operador. Con el debido cuidado, le brindará muchos años de sólido y eficiente funcionamiento.

### **⚠ ADVERTENCIA**

Para reducir el riesgo de lesiones, el usuario debe leer y comprender el manual del operador antes de usar este producto.

Le agradecemos la compra de un producto RIDGID®.

**GUARDE ESTE MANUAL PARA  
FUTURAS CONSULTAS**

# TABLE OF CONTENTS

## TABLE DES MATIÈRES / ÍNDICE DE CONTENIDO

---

■ Introduction .....	2
Introduction / Introducción	
■ General Safety Rules .....	3-4
Règles de sécurité générales / Reglas de seguridad generales	
■ Specific Safety Rules.....	4
Règles de sécurité particulières / Reglas de seguridad específicas	
■ Symbols.....	5
Symboles / Símbolos	
■ Electrical .....	6
Caractéristiques électriques / Aspectos eléctricos	
■ Features.....	7
Caractéristiques / Características	
■ Assembly .....	7-8
Assemblage / Armado	
■ Operation.....	8-9
Utilisation / Funcionamiento	
■ Maintenance.....	9
Entretien / Mantenimiento	
■ Warranty .....	10
Garantie / Garantía	
■ Figure numbers (illustrations) .....	11-12
Figure numéros (illustrations) / Figura numeras (ilustraciones)	
■ Parts Ordering and Service .....	Back Page
Commande de pièces et réparation / Pedidos de piezas y servicio .....	Page arrière / Pág. posterior

## INTRODUCTION

### INTRODUCTION / INTRODUCCIÓN

---

This product has many features for making its use more pleasant and enjoyable. Safety, performance, and dependability have been given top priority in the design of this product making it easy to maintain and operate.

\* \* \*

Ce produit offre de nombreuses fonctions destinées à rendre son utilisation plus plaisante et satisfaisante. Lors de la conception de ce produit, l'accent a été mis sur la sécurité, les performances et la fiabilité, afin d'en faire un outil facile à utiliser et à entretenir.

\* \* \*

Este producto ofrece numerosas características para hacer más agradable y placentero su uso. En el diseño de este producto se ha conferido prioridad a la seguridad, el desempeño y la fiabilidad, por lo cual se facilita su manejo y mantenimiento.

# GENERAL SAFETY RULES

## **WARNING:**

**Read and understand all instructions.** Failure to follow all instructions listed below, may result in electric shock, fire and/or serious personal injury.

## SAVE THESE INSTRUCTIONS

### WORK AREA

- **Keep your work area clean and well lit.** Cluttered benches and dark areas invite accidents.
- **Do not operate power tools in explosive atmospheres, such as in the presence of flammable liquids, gases, or dust.** Power tools create sparks which may ignite the dust or fumes.
- **Keep bystanders, children, and visitors away while operating a power tool.** Distractions can cause you to lose control.

### ELECTRICAL SAFETY

- **Double insulated tools are equipped with a polarized plug (one blade is wider than the other). This plug will fit in a polarized outlet only one way. If the plug does not fit fully in the outlet, reverse the plug. If it still does not fit, contact a qualified electrician to install a polarized outlet. Do not change the plug in any way.** Double insulation  eliminates the need for the three-wire grounded power cord and grounded power supply system.
- **Avoid body contact with grounded surfaces such as pipes, radiators, ranges, and refrigerators.** There is an increased risk of electric shock if your body is grounded.
- **Don't expose power tools to rain or wet conditions.** Water entering a power tool will increase the risk of electric shock.
- **Do not abuse the cord. Never use the cord to carry the tools or pull the plug from an outlet. Keep cord away from heat, oil, sharp edges, or moving parts. Replace damaged cords immediately.** Damaged cords increase the risk of electric shock.
- **When operating a power tool outside, use an outdoor extension cord marked "W-A" or "W".** These cords are rated for outdoor use and reduce the risk of electric shock.

### PERSONAL SAFETY

- **Stay alert, watch what you are doing and use common sense when operating a power tool. Do not use tool while tired or under the influence of drugs, alcohol, or medication.** A moment of inattention while operating power tools may result in serious personal injury.
- **Dress properly. Do not wear loose clothing or jewelry. Contain long hair. Keep your hair, clothing, and gloves away from moving parts.** Loose clothes, jewelry, or long hair can be caught in moving parts.

- **Avoid accidental starting. Be sure switch is off before plugging in.** Carrying tools with your finger on the switch or plugging in tools that have the switch on invites accidents.
- **Remove adjusting keys or wrenches before turning the tool on.** A wrench or a key that is left attached to a rotating part of the tool may result in personal injury.
- **Do not overreach. Keep proper footing and balance at all times.** Proper footing and balance enables better control of the tool in unexpected situations.
- **Use safety equipment. Always wear eye protection.** Dust mask, nonskid safety shoes, hard hat, or hearing protection must be used for appropriate conditions.
- **Do not wear loose clothing or jewelry. Contain long hair.** Loose clothes, jewelry, or long hair can be drawn into air vents.
- **Do not use on a ladder or unstable support.** Stable footing on a solid surface enables better control of the tool in unexpected situations.

### TOOL USE AND CARE

- **Use clamps or other practical way to secure and support the workpiece to a stable platform.** Holding the work by hand or against your body is unstable and may lead to loss of control.
- **Do not force tool. Use the correct tool for your application.** The correct tool will do the job better and safer at the rate for which it is designed.
- **Do not use tool if switch does not turn it on or off.** Any tool that cannot be controlled with the switch is dangerous and must be repaired.
- **Disconnect the plug from power source before making any adjustments, changing accessories, or storing the tool.** Such preventive safety measures reduce the risk of starting the tool accidentally.
- **Store idle tools out of the reach of children and other untrained persons.** Tools are dangerous in the hands of untrained users.
- **Maintain tools with care. Keep cutting tools sharp and clean.** Properly maintained tools with sharp cutting edges are less likely to bind and are easier to control.
- **Check for misalignment or binding of moving parts, breakage of parts, and any other condition that may affect the tool's operation. If damaged, have the tool serviced before using.** Many accidents are caused by poorly maintained tools.
- **Use only accessories that are recommended by the manufacturer for your model.** Accessories that may be suitable for one tool, may become hazardous when used on another tool.
- **Keep the tool and its handle dry, clean and free from oil and grease.** Always use a clean cloth when cleaning. Never use brake fluids, gasoline, petroleum-based products, or any strong solvents to clean your tool. Following this rule will reduce the risk of loss of control and deterioration of the enclosure plastic.

# GENERAL SAFETY RULES

---

## SERVICE

- Tool service must be performed only by qualified repair personnel. Service or maintenance performed by unqualified personnel may result in a risk of injury.

---

### WARNING!

To reduce the risk of injury, user must read instruction manual.

---

- When servicing a tool, use only identical replacement parts. Follow instructions in the Maintenance section of this manual. Use of unauthorized parts or failure to follow Maintenance Instructions may create a risk of shock or injury.

## SPECIFIC SAFETY RULES

---

- Hold tool by insulated gripping surfaces when performing an operation where the cutting tool may contact hidden wiring or its own cord. Contact with a “live” wire will make exposed metal parts of the cutting tool “live” and shock the operator.
- Know your power tool. Read operator’s manual carefully. Learn its applications and limitations, as well as the specific potential hazards related to this tool. Following this rule will reduce the risk of electric shock, fire, or serious injury.
- Always wear safety glasses. Everyday eyeglasses have only impact-resistant lenses; they are NOT safety glasses. Following this rule will reduce the risk of serious personal injury.
- Protect your lungs. Wear a face or dust mask if the operation is dusty. Following this rule will reduce the risk of serious personal injury.
- Protect your hearing. Wear hearing protection during extended periods of operation. Following this rule will reduce the risk of serious personal injury.
- Inspect tool cords periodically and, if damaged, have repaired at your nearest authorized service center. Constantly stay aware of cord location. Following this rule will reduce the risk of electric shock or fire.
- Check damaged parts. Before further use of the tool, a guard or other part that is damaged should

be carefully checked to determine that it will operate properly and perform its intended function. Check for alignment of moving parts, binding of moving parts, breakage of parts, mounting, and any other conditions that may affect its operation. A guard or other part that is damaged should be properly repaired or replaced by an authorized service center. Following this rule will reduce the risk of shock, fire, or serious injury.

- Make sure your extension cord is in good condition. When using an extension cord, be sure to use one heavy enough to carry the current your product will draw. A wire gauge size (A.W.G.) of at least 14 is recommended for an extension cord 50 feet or less in length. A cord exceeding 100 feet is not recommended. If in doubt, use the next heavier gauge. The smaller the gauge number, the heavier the cord. An undersized cord will cause a drop in line voltage resulting in loss of power and overheating.
- Inspect for and remove all nails from lumber before using this tool. Following this rule will reduce the risk of serious personal injury.
- Save these instructions. Refer to them frequently and use them to instruct others who may use this tool. If you loan someone this tool, loan them these instructions also.

## CALIFORNIA PROPOSITION 65

---

### WARNING:

This product and some dust created by power sanding, sawing, grinding, drilling, and other construction activities may contain chemicals, including lead, known to the State of California to cause cancer, birth defects, or other reproductive harm. **Wash hands after handling.** Some example of these chemicals are:



- lead from lead-based paints,
- crystalline silica from bricks and cement and other masonry products, and
- arsenic and chromium from chemically-treated lumber.

Your risk from these exposures varies, depending on how often you do this type of work. To reduce your exposure to these chemicals: work in a well ventilated area, and work with approved safety equipment, such as those dust masks that are specially designed to filter out microscopic particles.







---

# SYMBOLS

The following signal words and meanings are intended to explain the levels of risk associated with this product.

SYMBOL	SIGNAL	MEANING
	<b>DANGER:</b>	Indicates an imminently hazardous situation, which, if not avoided, will result in death or serious injury.
	<b>WARNING:</b>	Indicates a potentially hazardous situation, which, if not avoided, could result in death or serious injury.
	<b>CAUTION:</b>	Indicates a potentially hazardous situation, which, if not avoided, may result in minor or moderate injury.
	<b>CAUTION:</b>	(Without Safety Alert Symbol) Indicates a situation that may result in property damage.

Some of the following symbols may be used on this tool. Please study them and learn their meaning. Proper interpretation of these symbols will allow you to operate the tool better and safer.

SYMBOL	NAME	DESIGNATION/EXPLANATION
	Safety Alert	Indicates a potential personal injury hazard.
V	Volts	Voltage
A	Amperes	Current
Hz	Hertz	Frequency (cycles per second)
min	Minutes	Time
~	Alternating Current	Type of current
$n_0$	No Load Speed	Rotational speed, at no load
	Class II Tool	Double-insulated construction
.../min	Per Minute	Revolutions, strokes, surface speed, orbits etc., per minute
	Wet Conditions Alert	Do not expose to rain or use in damp locations.
	Read The Operator's Manual	To reduce the risk of injury, user must read and understand operator's manual before using this product.
	Eye Protection	Always wear eye protection with side shields marked to comply with ANSI Z87.1 and a full face shield when operating this product.
	Hot Surface	To reduce the risk of injury or damage, avoid contact with any hot surface.

# ELECTRICAL

## DOUBLE INSULATION

Double insulation is a concept in safety in electric power tools, which eliminates the need for the usual three-wire grounded power cord. All exposed metal parts are isolated from the internal metal motor components with protecting insulation. Double insulated tools do not need to be grounded.

### **WARNING:**

The double insulated system is intended to protect the user from shock resulting from a break in the tool's internal insulation. Observe all normal safety precautions to avoid electrical shock.

**NOTE:** Servicing of a product with double insulation requires extreme care and knowledge of the system and should be performed only by a qualified service technician. For service, we suggest you return the product to your nearest authorized service center for repair. Always use original factory replacement parts when servicing.

## ELECTRICAL CONNECTION

This product has a precision-built electric motor. It should be connected to a power supply that is **120 V, AC only (normal household current), 60 Hz**. Do not operate this product on direct current (DC). A substantial voltage drop will cause a loss of power and the motor will overheat. If the product does not operate when plugged into an outlet, double-check the power supply.

## EXTENSION CORDS

When using a power tool at a considerable distance from a power source, be sure to use an extension cord that has the capacity to handle the current the product will draw. An undersized cord will cause a drop in line voltage, resulting in overheating and loss of power. Use the chart to determine the minimum wire size required in an extension cord. Only round jacketed cords listed by Underwriter's Laboratories (UL) should be used.

When working outdoors with a product, use an extension cord that is designed for outside use. This type of cord is designated with "W-A" or "W" on the cord's jacket.

Before using any extension cord, inspect it for loose or exposed wires and cut or worn insulation.

\*\*Ampere rating (on product data plate)

Cord Length	Wire Size (A.W.G.)					
	0-2.0	2.1-3.4	3.5-5.0	5.1-7.0	7.1-12.0	12.1-16.0
25'	16	16	16	16	14	14
50'	16	16	16	14	14	12
100'	16	16	14	12	10	—

\*\*Used on 12 gauge - 20 amp circuit.

**NOTE:** AWG = American Wire Gauge

### **WARNING:**

Keep the extension cord clear of the working area. Position the cord so that it will not get caught on lumber, tools, or other obstructions while you are working with a power tool. Failure to do so can result in serious personal injury.

### **WARNING:**

Check extension cords before each use. If damaged replace immediately. Never use the product with a damaged cord since touching the damaged area could cause electrical shock resulting in serious injury.



# FEATURES

---

## PRODUCT SPECIFICATIONS

Bit Shank ..... 1/4 in.  
Switch.....Variable Speed  
No Load Speed .....0-4,000/min.

Input ..... 120 V, 60 Hz, AC only, 6.5 Amps  
Net Weight..... 3.1 lbs.

## KNOW YOUR DRYWALL SCREWDRIVER

See Figure 1, page 11.

The safe use of this product requires an understanding of the information on the product and in this operator's manual as well as a knowledge of the project you are attempting. Before use of this product, familiarize yourself with all operating features and safety rules.

### ADJUSTABLE NOSEPIECE

Your screwdriver has an adjustable nosepiece for varying screw depth and easy bit changes.

### BELT CLIP

A convenient belt clip is located on top of the motor housing.

### DUAL GRIP HANDLE

The soft-grip handle is designed with two grip position options for operator comfort and ease of handling.

## FORWARD/REVERSE LEVER

The forward/reverse lever changes the direction of bit rotation.

## LOCK-ON BUTTON

The lock-on feature allows for continuous driving of screws for extended periods of time.

## MAGNETIC BIT HOLDER

The magnet holds the screwdriver bit and screws until you are ready to drive them into drywall.

## SWITCH TRIGGER

The switch trigger for your drywall screwdriver is conveniently located on the handle of the tool.

## VARIABLE SPEED

The variable speed switch delivers higher speed with increased trigger pressure.

# ASSEMBLY

---

## UNPACKING

This product has been shipped completely assembled.

- Carefully remove the tool and any accessories from the box. Make sure that all items listed in the packing list are included.

---

### WARNING:

Do not use this product if it is not completely assembled or if any parts appear to be missing or damaged. Use of a product that is not properly and completely assembled could result in serious personal injury.

- 
- Inspect the tool carefully to make sure no breakage or damage occurred during shipping.
  - Do not discard the packing material until you have carefully inspected and satisfactorily operated the tool.
  - If any parts are damaged or missing, please call 1-866-539-1710 for assistance.

## PACKING LIST

Drywall Screwdriver with Magnetic Bit Holder  
and #2 Phillips Bit installed  
R2 Square Recess Screwdriver Bit  
Operator's Manual

---

### WARNING:

If any parts are missing do not operate this tool until the missing parts are replaced. Use of this product with damaged or missing parts could result in serious personal injury.

---

### WARNING:

Do not attempt to modify this tool or create accessories not recommended for use with this tool. Any such alteration or modification is misuse and could result in a hazardous condition leading to possible serious personal injury.

---

### WARNING:

Do not connect to power supply until assembly is complete. Failure to comply could result in accidental starting and possible serious personal injury.

---

# ASSEMBLY

---

## INSTALLING AND REPLACING BIT HOLDER AND BITS

See Figure 2, page 11.

### To install or replace bits:

- Install 1/4 in. screwdriver bits by inserting them into the magnetic bit holder.

**NOTE:** It is not necessary to remove the adjustable nose-piece to install or remove bits.

- Replace 1/4 in. screwdriver bits by pulling them out of the magnetic bit holder.

### To remove the magnetic bit holder:

- Pull the adjusting sleeve. The adjusting sleeve and adjustable nosepiece come off the gear casing as a set.
- Remove the magnetic bit holder. Pull the bit holder out with pliers if you cannot remove it by hand.

### To reassemble the bit holder and nosepiece:

- Push the bit holder into the hex opening of the spindle until the ball lock snaps into the groove in the bit holder shank.
- Attach the adjustable nosepiece to the gear case. Align the raised tab inside the adjustable nosepiece with the groove on the gear case and push the nosepiece until it snaps into place.

# OPERATION

---

## WARNING:

Do not allow familiarity with tools to make you careless. Remember that a careless fraction of a second is sufficient to inflict severe injury.

## WARNING:

Always wear eye protection with side shields marked to comply with ANSI Z87.1. Failure to do so could result in objects being thrown into your eyes, resulting in possible serious injury.

## WARNING:

Do not use any attachments or accessories not recommended by the manufacturer of this tool. The use of attachments or accessories not recommended can result in serious personal injury.

## APPLICATIONS

You may use this tool for the purposes listed below:

- Driving screws in drywall

## STARTING/STOPPING THE SCREWDRIVER

See Figure 3, page 11.

To turn the screwdriver **ON**, depress the switch trigger. Release the switch trigger to turn the screwdriver **OFF**.

## VARIABLE SPEED

The screwdriver has a variable speed switch for operator control of speed and torque limits.

Depress the switch trigger all the way for maximum speed and torque. Depress the switch trigger only part of the way for less speed and torque.

Avoid running the tool at low speeds for extended periods of time. Constant use at low speeds may cause overheating. If this occurs, cool the screwdriver by running it without a load and at full speed.

## LOCK-ON BUTTON

See Figure 3, page 11.

The screwdriver is equipped with a lock-on feature which is convenient for continuous driving of screws for extended periods of time. To lock-on, depress the switch trigger, push in and hold the lock-on button located on the side of the handle, then release switch trigger. Release the lock-on button and the screwdriver will continue running.

To release the lock, depress the switch trigger and release.

If you have the lock-on feature engaged during use and the screwdriver becomes disconnected from the power supply, disengage the lock-on feature immediately.

## FORWARD/REVERSE LEVER

See Figure 4, page 11.

The direction of rotation of the bit is controlled by a lever located above the switch trigger. With the screwdriver held in normal operating position, the direction of rotation lever should be positioned to the left of the switch for forward driving operation. The direction of rotation is in reverse when the lever is to the right of the switch.

**NOTE:** The screwdriver will not run unless forward/reverse lever is pushed fully to the left or right. The design of the switch will not permit changing the direction of rotation while the screwdriver is running. Release the switch trigger and allow the screwdriver to stop before changing its direction.



# OPERATION

---

## SETTING DEPTH

See Figure 5, page 12.

The adjustable nosepiece of your tool will automatically drive screws to preset depths. It may be helpful to begin each new job by driving several test screws in scrap material to check and adjust the depth setting.

To make preset depth adjustments:

- Rotate the adjusting sleeve until you obtain the desired depth for the bit holder or screwdriver bit.
- Test drive a screw in scrap material to determine if it is correct.
- Adjust as necessary to increase or decrease the desired depth.

## DRIVING SCREWS

See Figures 6 - 7, page 12.

There are two two options for gripping the handle of the screwdriver, determined by operator comfort and working angle.

The screwdriver has a variable speed switch for operator control of speed and torque limits.

- Be sure the screwdriver is in the OFF position before connecting it to the power supply.
  - Check the direction of rotation lever for correct setting (forward or reverse).
  - Secure the workpiece. Use clamps if necessary.
  - Plug the screwdriver into power supply source.
  - Depress the switch trigger to start the screwdriver. Do not lock the switch ON for jobs where the screwdriver may need to be stopped suddenly.
  - Hold the screwdriver firmly and place the bit and screw at the point to be driven.
- NOTE:** The bit holder is magnetized and will hold most commercial drywall screws.
- Apply quick, snap action type pressure to the bit. The pressure applied will engage the clutch and drive the screw.

# MAINTENANCE

---

### **WARNING:**

When servicing use only identical RIDGID replacement parts. Use of any other parts may create a hazard or cause product damage.

---

### **WARNING:**

Always wear eye protection with side shields marked to comply with ANSI Z87.1. Failure to do so could result in objects being thrown into your eyes, resulting in possible serious injury.

---

## GENERAL MAINTENANCE

Avoid using solvents when cleaning plastic parts. Most plastics are susceptible to damage from various types of commercial solvents and may be damaged by their use. Use clean cloths to remove dirt, dust, oil, grease, etc.

---

### **WARNING:**

Do not at any time let brake fluids, gasoline, petroleum-based products, penetrating oils, etc., come in contact with plastic parts. Chemicals can damage, weaken or destroy plastic which may result in serious personal injury.

---

Electric tools used on fiberglass material, wallboard, spackling compounds, or plaster are subject to accelerated wear and possible premature failure because the fiberglass chips and grindings are highly abrasive to bearings, brushes, commutators, etc. Consequently, we do not recommended using this tool for extended work on these types of materials. However, if you do work with any of these materials, it is extremely important to clean the tool using compressed air.

## LUBRICATION

All of the bearings in this tool are lubricated with a sufficient amount of high grade lubricant for the life of the unit under normal operating conditions. Therefore, no further lubrication is required.

**Fig. 1**

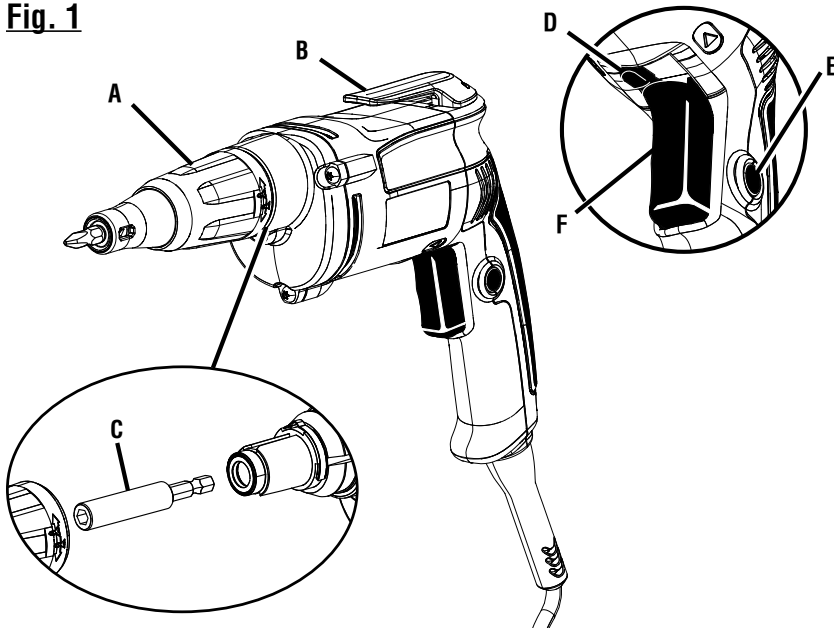

- A - Adjustable nosepiece (butée réglable, punta ajustable)
- B - Belt clip (clip de ceinture, clip para el cinto)
- C - Magnetic bit holder (porte embout magnétique, portapuntas magnético)
- D - Forward/reverse lever (inverseur de sens de rotation, palanca de marcha adelante/atrás)
- E - Lock-on button (bouton de verrouillage, botón del seguro de encendido)
- F - Switch trigger (gâchette de commutateur, gatillo del interruptor)

**Fig. 2**

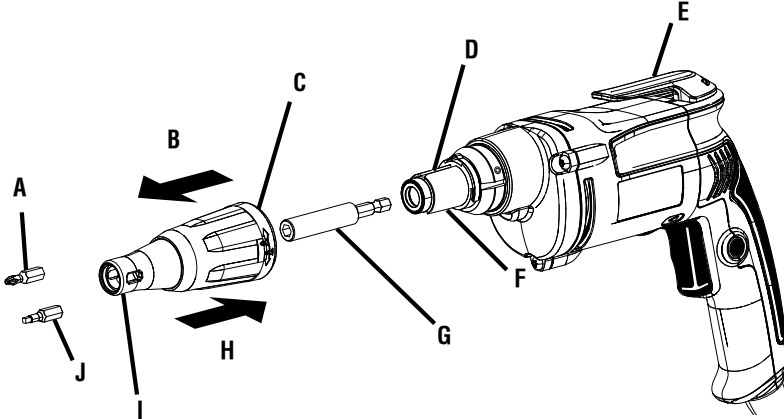

- A - 1/4 in. phillips screwdriver bit (embout philips de 6,4 mm [1/4 po], punta de destornillador phillips de 6,4 mm [1/4 pulg.])
- B - Pull to remove adjustable nosepiece (tirer pour enlever la tête réglable, para desmontar la punta ajustable, tire de la misma)
- C - Adjusting sleeve (manchon de réglage, collar de ajuste)
- D - Groove (rainure, ranura)
- E - Belt clip (clip de ceinture, clip para el cinto)
- F - Gear casing (boîtier d'engrenages, caja de engranajes)
- G - Magnetic bit holder with 1/4 in. hex opening (porte-embout magnétique avec ouverture hexagonale de 6,4 mm [1/4 po]; portapuntas magnético con abertura hexagonal de 6,4 mm [1/4 pulg.])
- H - Align and push to replace adjustable nosepiece (aligner la tête réglable et appuyer pour la remettre en place, para volver a montar la punta ajustable, alinéela y empújela)
- I - Adjustable nosepiece (tête réglable, punta ajustable)
- J - R2 bit (embout r2, punta r2)

**Fig. 3**

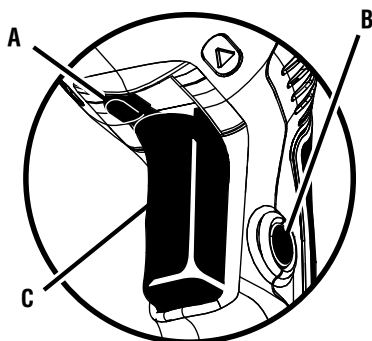

- A - Forward/reverse lever (inverseur de sens de rotation, palanca de marcha adelante/atrás)
- B - Lock-on button (bouton de verrouillage, botón del seguro de encendido)
- C - Switch trigger (gâchette de commutateur, gatillo del interruptor)

**Fig. 4**

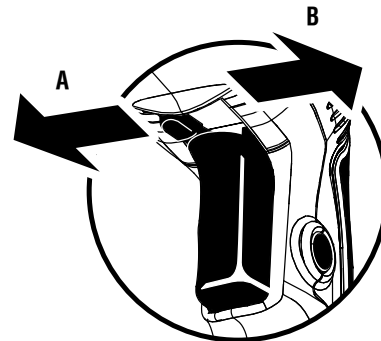

- A - Reverse (marche arrière, marcha atrás)
- B - Forward (marche avant, marcha adelante)

**Fig. 5**

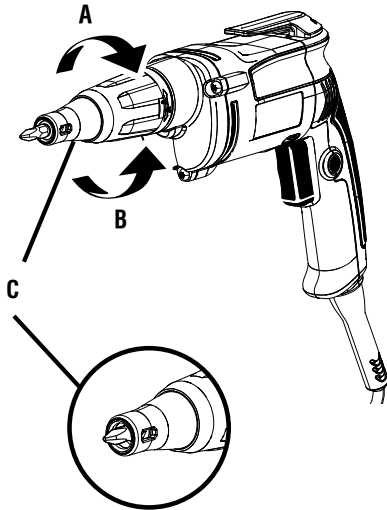

- A - To decrease depth of screwdriver bit (pour réduire la profondeur de l'embout, para disminuir la profundidad de la punta de destornillador)
- B - To increase depth of screwdriver bit (pour augmenter la profondeur de l'embout, para aumentar la profundidad de la punta de destornillador)
- C - Preset depth setting of screwdriver bit (réglage de la profondeur de l'embout, profundidad prefijada de la punta de destornillador)

**Fig. 6**

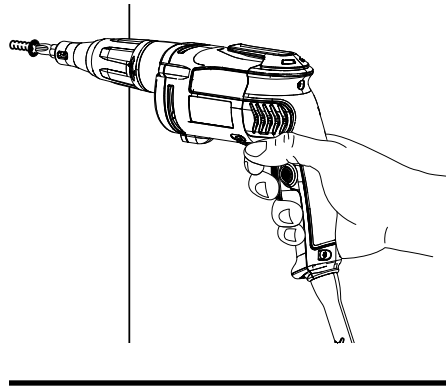

**Fig. 7**

