

VerifEye™ Series 2000 Three Phase Meter Kits

Submetering Solutions for Accurate Measurement & Verification



- kWh meter and optional demand reset
- 120/208V or 277/480V 3PH 4W WYE only
- 100-1200 Amps
- Pulse output—standard feature
- Large LCD display
- Kit includes submeter and required Current Transformers (CTs)

DESCRIPTION

The Leviton VerifEye™ Series 2000 line of revenue-grade meters meets all measurement and verification-based opportunities including load management and LEED rating achievement. Designed to provide a simple and effective process for accurately capturing measurements of power consumption, Series 2000 meters are easy to specify and install for new construction and retrofits.

Leviton meters utilize highly accurate current transformers for revenue-grade performance certified to ANSI standards. Competing products use current sensors that do not provide the same level of performance. Leviton offers Current Transformers (CTs) in solid and split core styles to accommodate all phases of installation and construction.

Solid core CTs are ideal for new construction, when power is not live and wires can easily be threaded through the core. Split core CTs can be installed at any time without having to disconnect wire terminations, making them the optimal choice for retrofitting an existing structure.

Split core CTs close securely for fast, precise installation with no need for time-consuming tie wraps and no worries about improper seating or core half separation. Both solid and split core CTs offer high quality, long term accuracy and reliability.

Every Series 2000 meter has an installer-friendly feedback feature. The red reverse phase indicator acts as an installation diagnostics tool and illuminates if a meter is improperly installed. After installation, the green duty cycle light shows that the meter is collecting electrical consumption data at the appropriate rate. All 100 and 200 Amp solid core CTs have color-coded labels to easily identify correct line/load orientation.

APPLICATIONS

Use Series 2000 meters in commercial, institutional, industrial and government applications for:

- Load profiling and benchmarking
- AMR integration
- Usage aggregation
- Tenant cost allocation
- Measurement and verification
- Energy conservation and cost reduction
- Green building initiatives and government mandates

Current Transformers

Submetering Solutions for Accurate Measurement & Verification



DEFINITION

Leviton Current Transformers (CTs) support our full line of VerifEye™ revenue-grade meters and help meet all measurement and verification-based opportunities—including smart metering and LEED rating achievement. Designed as part of a simple and effective process for accurately capturing measurements of power consumption, CTs are easy to specify and install for new construction and retrofits.

The better the equipment, the better the measurement. Leviton meters utilize highly accurate current transformers for revenue-grade performance certified to ANSI standards. Competing products use current sensors that do not provide the same level of performance. CTs come as solid core standard for high-quality, long-term accuracy and reliability. Solid core CTs deliver +/-0.3% accuracy. Split core and Rogowski Coil CTs deliver +/-1.0% accuracy. For added safety, all Leviton current transformers come with built-in voltage suppression devices that prevent hazardous voltages from developing on CT secondaries should they become disconnected from a meter with load current present. Leviton CTs are UL and cUL listed devices.

SOLID CORE

Leviton solid core CTs are cost effective and less susceptible to damage during installation. Solid core CTs slip over power lines to measure the electrical current flowing through the line. The CT “secondary” wires connect to the meter facilitating power and energy calculations. They are compact and cost effective. Solid core CTs are accurate (0.3% maximum error). For installation, power must be de-energized and the circuit opened in order to slip the CT over the power line.

SPLIT CORE

Split core CTs can be disassembled or ‘split’ into halves eliminating the need to turn power off and open the circuit during installation. This time-saving installation is ideal for critical loads that cannot be disconnected. Split core CTs close securely for fast, precise installation with no need for time-consuming tie wraps and no worries about improper seating or core half separation.

- Indoor type for measurement category Class IV, accessory equipment for energy meters
- Designed to meet the requirements of UL916 plus CSA C22.2 No. 61010-1
- Suitable for installation on 600V uninsulated bus duct

ROGOWSKI COIL

Rogowski Coil CTs are flexible rope style CTs with high amperage ranges from 20-5000A. The coil opens at the connector junction for fast and easy installation into an existing cable or bus bar. The Rogowski Coil’s flexible core is ideal for tight enclosures and odd-sized conductors with three length options: 12”, 18” and 24”. Rogowski Coil CTs are for use with VerifEye Series 4000 Industrial ModBus Meter Kits only.

APPLICATIONS

Use current transformers in commercial, institutional, industrial and government applications to support:

- Load profiling and benchmarking
- AMR/BAS/BMS/EMS integration
- Power quality analysis
- Usage aggregation
- Tenant cost allocation
- Measurement and verification
- Net metering
- Energy conservation and cost reduction
- Green building initiatives and government mandates

DIMENSIONAL DIAGRAMS

SPLIT CORE—FOR USE WITH SERIES 1000, 2000, 3500, 8000 METERS AND SERIES 2000 MULTIPLE METER UNITS (MMUs) ONLY

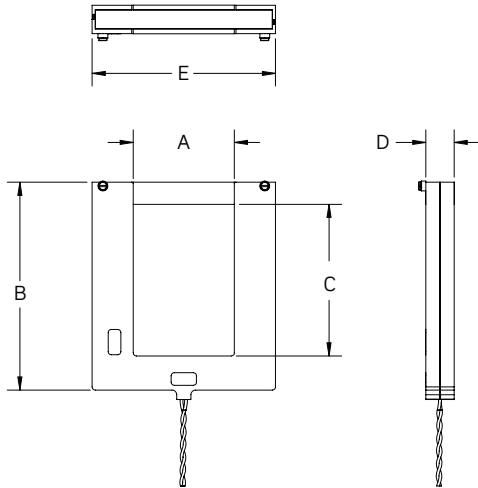

SPLIT CORE—FOR USE WITH SERIES 1000, 2000, 3500, 8000 METERS AND SERIES 2000 MULTIPLE METER UNITS (MMUs) ONLY

CT Size	A	B	C	D	E
100:0.1A	0.75" (19.05mm)	2.53" (64.16mm)	0.75" (19.05mm)	0.95" (24.13mm)	2.58" (65.53mm)
200:0.1A	1.00" (25.4mm)	2.86" (72.64mm)	1.00" (25.4mm)	0.75" (19.05mm)	2.75" (69.85mm)
400:0.1A	1.50" (38.1mm)	3.31" (84.07mm)	1.50" (38.1mm)	1.07" (27.18mm)	3.74" (95mm)
800:0.1A	3.00" (76.2mm)	5.38" (136.65mm)	3.50" (88.9mm)	1.25" (31.75mm)	5.39" (136.91mm)
1200:0.1A	4.00" (101.6mm)	8.23" (209.04mm)	6.00" (152.4mm)	1.12" (28.45mm)	7.25" (184.15mm)
1600:0.1A	4.00" (101.6mm)	8.23" (209.04mm)	6.00" (152.4mm)	1.12" (28.45mm)	7.25" (184.15mm)
3000:0.1A	5.00" (127mm)	9.86" (250.44mm)	7.00" (177.8mm)	1.44" (36.58mm)	8.44" (214.38mm)
5000:0.1A	5.00" (127mm)	9.86" (250.44mm)	7.00" (177.8mm)	1.44" (36.58mm)	8.44" (214.38mm)

SPLIT CORE—FOR USE WITH EMH+ AND SERIES 4000 & 4100 INDUSTRIAL MODBUS METER KITS ONLY

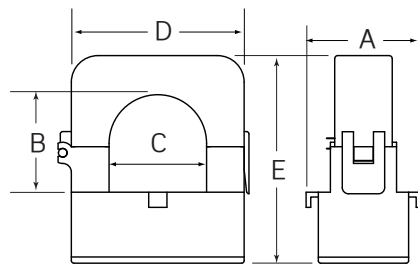

100 & 200A

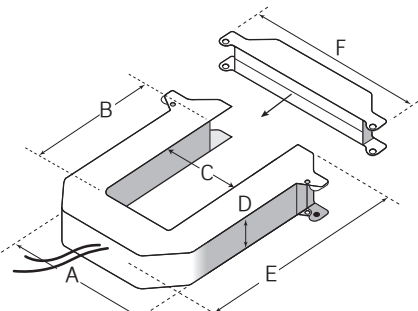

400 & 800A

SPLIT CORE—FOR USE WITH EMH+ AND SERIES 4000 & 4100 INDUSTRIAL MODBUS METER KITS ONLY

CT Size	A	B	C	D	E	F
100:0.333V	1.5" (38.10mm)	0.8" (20.32mm)	0.7" (17.78mm)	1.6" (40.64mm)	2.1" (53.34mm)	-
200:0.333V	1.5" (38.10mm)	1.25" (31.75mm)	1.25" (31.75mm)	2.25" (57.15mm)	2.8" (71.12mm)	-
400:0.333V & 800:0.333V	4.9" (124.46mm)	2.29" (58.16mm)	2.25" (63.5mm)	1.2" (30.48mm)	5.2" (132.08mm)	6.0" (152.40mm)

PRODUCT DATA

DIMENSIONAL DIAGRAMS
SOLID CORE—FOR USE WITH SERIES 8000 METERS, MINI METERS AND MMUs ONLY

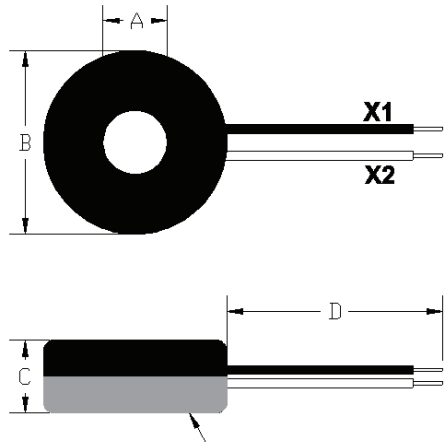

SOLID CORE—FOR USE WITH SERIES 8000 METERS, MINI METERS AND MMUs ONLY

CT Size	A	B	C	D
100:0.1A & 200:0.1A 0.67"	0.67" (17mm)	1.65" (42mm)	0.71" (18mm)	48.00" (1219mm)
100:0.1A & 200:0.1A 0.72"	0.72" (18.3mm)	2.06" (52.3mm)	0.82" (20.8mm)	48.00" (1219mm)
400:0.1A 1.5"	1.50" (38.1mm)	3.60" (76.2mm)	1.38" (34.9mm)	48.00" (1219mm)

NOTE: Lead lengths may be extended up to 500'. Consult factory for details

ROGOWSKI COIL—FOR USE WITH SERIES 4000 & 4100 INDUSTRIAL MODBUS METER KITS ONLY

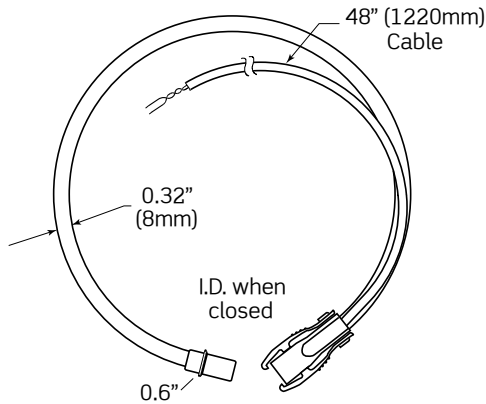

ROGOWSKI COIL—FOR USE WITH SERIES 4000 & 4100 INDUSTRIAL MODBUS METER KITS ONLY

LENGTH	INSIDE DIAMETER WITH CLOSED CONNECTOR
12" (305mm)	3.85" (98mm)
18" (458mm)	5.75" (147mm)
24" (610mm)	7.65" (195mm)

ORDERING INFORMATION

NOTE: Meters sold separately

Current Transformers

AMP	CAT. NO.	DESCRIPTION
SINGLES		
SOLID CORE—FOR USE WITH SERIES 8000 METERS, MINI METERS AND MMUs ONLY		
100:0.1A	CDE01-K11	Solid Core, 0.67", Black
100:0.1A	CDE01-L11	Solid Core, 0.67", Blue
100:0.1A	CDE01-R11	Solid Core, 0.67", Red
100:0.1A	CDA01-K12	Solid Core, 0.72", Black
100:0.1A	CDA01-L12	Solid Core, 0.72", Blue
100:0.1A	CDA01-R12	Solid Core, 0.72", Red
200:0.1A	CDE02-K11	Solid Core, 0.67", Black
200:0.1A	CDE02-L11	Solid Core, 0.67", Blue
200:0.1A	CDE02-R11	Solid Core, 0.67", Red
200:0.1A	CDA02-K12	Solid Core, 0.72", Black
200:0.1A	CDA02-L12	Solid Core, 0.72", Blue
200:0.1A	CDA02-R12	Solid Core, 0.72", Red
400:0.1A	CDF04-K24	Solid Core, 1.5", Black
SPLIT CORE—SERIES 1000, 2000, 3500 METERS, SERIES 8000 METERS AND SERIES 2000 (MMUs) ONLY		
100:0.1A	CTD01-K16	Split Core, .75" x .75"
200:0.1A	CTD02-K16	Split Core, 1" x 1"
400:0.1A	CTD04-K23	Split Core, 1.5", x 1.5"
800:0.1A	CTC08-K46	Split Core, 3" x 3.5"
1200:0.1A	CTC12-K46	Split Core, 4" x 6"
1600:0.1A	CTC16-K96	Split Core, 4" x 6"
3000:0.1A	CTC30-57B	Split Core, 5" x 7"
5000:0.1A	CTC50-57B	Split Core, 5" x 7"
SPLIT CORE—FOR USE WITH EMH+ AND SERIES 4000 & 4100 INDUSTRIAL MODBUS METER KITS ONLY		
100:0.333V	CTV01-K21	Split Core, 1.6" x 2.1"
200:0.333V	CTV02-K21	Split Core, 2.2" x 2.8"
400:0.333V	CTV04-K40	Split Core, 6" x 5.2"
800:0.333V	CTV08-K40	Split Core, 6" x 5.2"
ROGOWSKI COIL—FOR USE WITH SERIES 4000 & 4100 INDUSTRIAL MODBUS METER KITS ONLY		
20-5000A	CRV50-K62	Rogowski Coil, 12"
20-5000A	CRV50-K93	Rogowski Coil, 18"
20-5000A	CRV50-KC2	Rogowski Coil, 24"

AMP	CAT. NO.	DESCRIPTION
KITS—FOR USE WITH MINI-METERS AND MMUs ONLY		
100:0.1A	CDE01-211	CT Kit, 0.67", Red, Black
100:0.1A	CDE01-311	CT Kit, 0.67", Blue, Red, Black
100:0.1A	CDA01-212	CT Kit, 0.72", Red, Black
100:0.1A	CDA01-312	CT Kit, 0.72", Blue, Red, Black
200:0.1A	CDE02-211	CT Kit, 0.67", Red, Black
200:0.1A	CDE02-311	CT Kit, .067", Blue, Red, Black
200:0.1A	CDA02-212	CT Kit, 0.72", Red, Black
200:0.1A	CDA02-312	CT Kit, 0.72", Blue, Red, Black

Leviton recommends solid core transformers (CTs) for revenue-grade accuracy. Our 100A and 200A color coded CTs assist with correct installation by indicating phase monitored. Split core CTs are also available upon request for applications where power cannot be interrupted during installation. Our 100-5,000A split core and 20-5000A Rogowski Coil CTs offer +/-1.0% accuracy.

The following products are also part of the Leviton line of VerifEye integrated metering solutions:

- Series 1000 Meters
- Series 2000 Meters
- Series 3500 Meters
- Series 4000 & 4100 Industrial ModBus Meter Kits
- Series 8000 Meters
- EMH+ Integrated Meter & Hub
- Mini Meters
- Multiple Meter Units (MMUs)
- Energy Monitoring Software and Hardware

PRODUCT DATA

FEATURES

- Measures kWh and demand (optional)
- Conform to all applicable standards of ANSI C12.1
- Equipped standard with an Isolated Pulse Output channel
- Utilizes either revenue grade 0.5% accuracy class 0.1A secondary solid core CTs that conform to all applicable ANSI requirements or 1.0% accuracy split core CTs
- Up to three sets of CTs per phase can be paralleled per meter without the need for a meter multiplier
- Enclosure options include surface mount industrial grade JIC steel indoor and NEMA 4X outdoor
- Interfaces with numerous communication systems
 - Hardwired Automatic Meter Reading (AMR) or wireless AMR
- Large LCD display shows kWh and optional peak and instantaneous kW with Demand Reset
- Load Indicator LED verifies meter functionality
- Reverse Phase Indicator LED illuminates if the meter is improperly installed
- CT lead length maximum: 48"
- UL/cUL Listed Energy Usage Monitor per CCN FTR7
- Ten year warranty

CONFIGURATIONS*

AMPERAGES	PHASE/VOLTAGES
100-1200A	30/4W - 120/208/240V
100-1200A	30/4W - 277/480V

* Contact factory for non-US voltage configurations.

THREE ELEMENT SERIES 2000 HOOKUP DIAGRAM

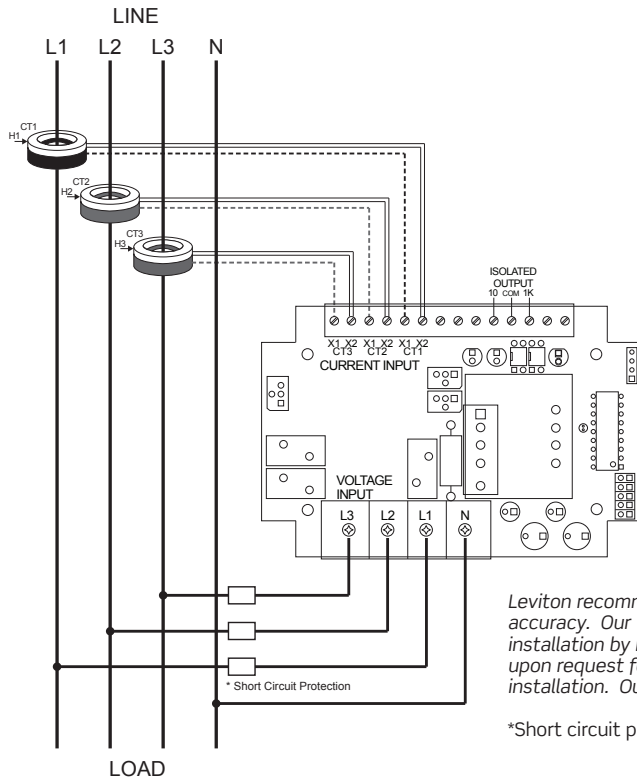

Leviton recommends solid core transformers (CTs) for revenue-grade accuracy. Our 100A and 200A color coded CTs assist with correct installation by indicating phase monitored. Split core CTs are also available upon request for applications where power cannot be interrupted during installation. Our 100-1, 200 Amp Split Core CTs offer +/-1.0% accuracy.

*Short circuit protection per NEC and local codes by other.

**DIMENSIONS
INDOOR ENCLOSURE**

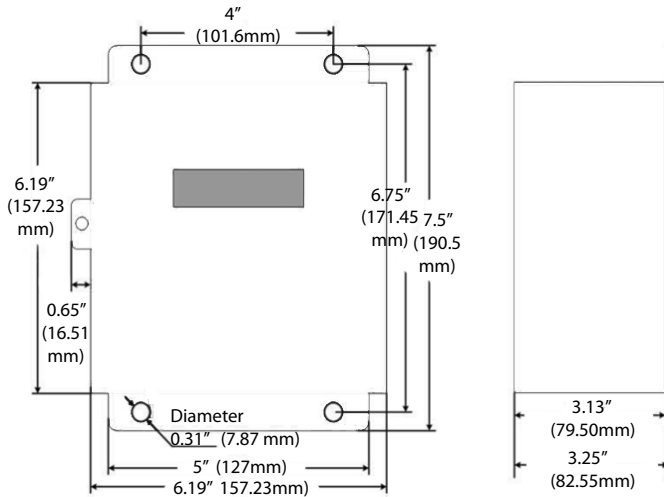

OUTDOOR ENCLOSURE

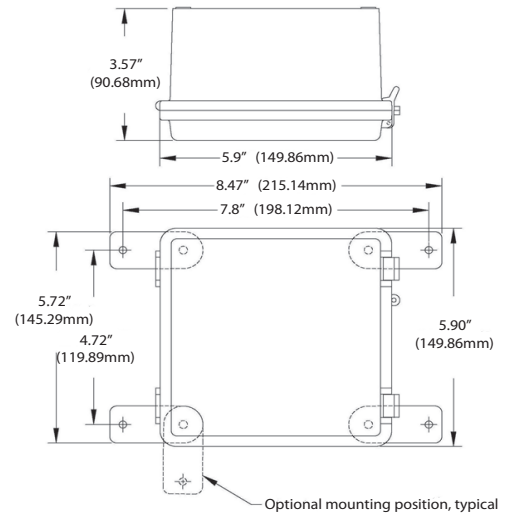

ORDERING INFORMATION

Series 2000 Three Phase Meter Kits—Indoor Enclosure

NOTE: All kits include meter, specified enclosure and Current Transformers (CTs)

Voltage	Amps	CTs Included	Leviton P/N
120/208V 3 PH 4 W WYE kWh Meter	100	3 Split CTs	2K208-01W
	200	3 Split CTs	2K208-02W
	400	3 Split CTs	2K208-04W
	800	3 Split CTs	2K208-08W
	1200	3 Split CTs	2K208-12W
	100	3 SOLID CTs	2K208-1SW
	200	3 SOLID CTs	2K208-2SW
277/480 3 PH 4 W WYE kWh Meter	100	3 Split CTs	2K480-01W
	200	3 Split CTs	2K480-02W
	400	3 Split CTs	2K480-04W
	800	3 Split CTs	2K480-08W
	1200	3 Split CTs	2K480-12W
	100	3 SOLID CTs	2K480-1SW
	200	3 SOLID CTs	2K480-2SW
120/208V 3 PH 4 W WYE Demand Meter	100	3 Split CTs	2K208-01D
	200	3 Split CTs	2K208-02D
	400	3 Split CTs	2K208-04D
	800	3 Split CTs	2K208-08D
	1200	3 Split CTs	2K208-12D
277/480V 3 PH 4 W WYE Demand Meter	100	3 Split CTs	2K480-01D
	200	3 Split CTs	2K480-02D
	400	3 Split CTs	2K480-04D
	800	3 Split CTs	2K480-08D
	1200	3 Split CTs	2K480-12D

VerifEye™ Series 2000 Three Phase Meter Kits

PRODUCT DATA



ORDERING INFORMATION, CONT'D

Series 2000 Three Phase Meter Kits Outdoor Enclosure

Voltage	Amps	CTs Included	Leviton P/N
120/208V 3 PH 4 W WYE kWh Meter	100	3 Split CTs	20208-01W
	200	3 Split CTs	20208-02W
	400	3 Split CTs	20208-04W
	800	3 Split CTs	20208-08W
	1200	3 Split CTs	20208-12W
277/480V 3 PH 4 W WYE kWh Meter	100	3 Split CTs	20480-01W
	200	3 Split CTs	20480-02W
	400	3 Split CTs	20480-04W
	800	3 Split CTs	20480-08W
	1200	3 Split CTs	20480-12W

Series 2000 Three Phase Standalone Meters

NOTE: Current Transformers (CTs) sold separately—see Current Transformers product data sheet for ordering information

Voltage	Leviton P/N
INDOOR THREE ELEMENT METER, 3PH 4W	
120/208V	2N208-xxx
277/480V	2N480-xxx
OUTDOOR THREE ELEMENT METER, 3PH 4W	
120/208V	2R208-xxx
277/480V	2R480-xxx

* When ordering a Series 2000 Standalone Meter, replace xxx with the following to indicate amperage ratings:

- 011: 100:0.1A, Max 100A
- 021: 200:0.1A, Max 200A
- 041: 400:0.1A, Max 400A
- 081: 800:0.1A, Max 800A
- 121: 1200:0.1A, Max 1200A
- Demand Option (for indoor models only): replace the last digit in the suffix with a "D"

The following products are also part of the Leviton line of integrated metering solutions:

Series 1000 Meters	Mini Meters
Series 3500 Meters	Multiple Meter Units (MMUs)
Series 4000/4100 Meters	Current Transformers (CTs)
Series 8000 Meters	Energy Monitoring Software and Hardware
EMH+ Meter & Hub	

VeriEye™ Series 2000 Three Phase Meter Kits