



# ***TEK-SUB 4800A***

## ***Plastic Submersible Level Transmitter***

---

### **Instruction Manual**

Document Number: IM-4800A



## Table of Contents

<b>1</b>	<b>Safety Instructions</b> .....	<b>2</b>
1.1	Intended Use .....	2
1.2	Safety Instructions from the Manufacturer .....	2
1.2.1	Disclaimer .....	2
1.2.2	Product Liability and Warranty .....	2
1.2.3	Information Concerning the Documentation.....	2
1.3	Safety Precautions .....	2
1.4	Packaging, Transportation and Storage.....	4
1.4.1	Packaging.....	4
1.4.2	Transportation.....	4
1.4.3	Nameplate.....	5
<b>2</b>	<b>Product Description</b> .....	<b>6</b>
2.1	Principle of Operation .....	6
2.2	Technical Specification .....	7
2.3	Dimensional Drawings .....	8
2.4	Model Chart.....	9
<b>3</b>	<b>Installation</b> .....	<b>9</b>
3.1	Considerations to be taken before Installation.....	9
3.2	Installation Methods.....	10
3.2.1	Installation in the Static Water .....	10
3.2.2	Installation in an Open Channel (eg. Reservoir Area, River Channel).....	11
<b>4</b>	<b>Electrical Connections</b> .....	<b>12</b>
<b>5</b>	<b>Operation</b> .....	<b>13</b>
<b>6</b>	<b>Maintenance</b> .....	<b>14</b>
<b>7</b>	<b>Troubleshooting</b> .....	<b>15</b>

# 1 Safety Instructions

## 1.1 Intended Use

This measuring device is intended to calculate the level of liquid in a tank by measuring the hydrostatic pressure in the tank.

## 1.2 Safety Instructions from the Manufacturer

### 1.2.1 Disclaimer

The manufacturer will not be held accountable for any damage that happens by using its product, including, but not limited to direct, indirect, or incidental and consequential damages.

Any product purchased from the manufacturer is warranted in accordance with the relevant product documentation and our Terms and Conditions of Sale.

The manufacturer has the right to modify the content of this document, including the disclaimer, at any time for any reason without prior notice, and will not be answerable in any way for the possible consequence of such changes.

### 1.2.2 Product Liability and Warranty

The operator shall bear authority for the suitability of the device for the specific application. The manufacturer accepts no liability for the consequences of misuse by the operator. Wrong installation or operation of the devices (systems) will cause the warranty to be void. The respective Terms and Conditions of Sale, which forms the basis for the sales contract shall also apply.

### 1.2.3 Information Concerning the Documentation

To prevent any injury to the operator or damage to the device it is essential to read the information in this document and the applicable national standard safety instructions. This operating manual contain all the information that is required in various stages, such as product identification, incoming acceptance and storage, mounting, connection, operation and commissioning, troubleshooting, maintenance, and disposal.

## 1.3 Safety Precautions

You must read these instructions carefully prior to installing and commissioning the device. These instructions are an important part of the product and must be kept for future reference. Only by observing these instructions, optimum protection of both personnel and the environment, as well as safe and fault-free operation of the device can be ensured.

For additional information that are not discussed in this manual, contact the manufacturer

### **Warnings and Symbols Used**

The following safety symbol marks are used in this operation manual and on the instrument.



#### **WARNING**

---

Indicates a potentially hazardous situation which, if not avoided, could result in death or serious injury

---



#### **CAUTION**

---

Indicates a potentially hazardous situation which, if not avoided, may result in minor or moderate injury. It may also be used to alert against unsafe practices.

---



#### **NOTE**

---

Indicates that operating the hardware or software in this manner may damage it or lead to system failure.

---

## 1.4 Packaging, Transportation and Storage

### 1.4.1 Packaging

The original package consists of

1. Tek-Sub 4800A PTFE Submersible Level Transmitter
2. Documentation



### 1.4.2 Transportation

- Avoid impact shocks to the device and prevent it from getting wet during transportation.
- Verify local safety regulations, directives, and company procedures with respect to hoisting, rigging, and transportation of heavy equipment.
- Transport the product to the installation site using the original manufacturer's packing whenever possible.

### 1.4.3 Nameplate

The nameplate lists the order number and other important information, such as design details and technical data



#### NOTE

---

Check the device nameplate to ensure that the device is delivered according to your order. Check for the correct supply voltage printed on the nameplate.

---



### **Tek-Sub 4800A**

#### PTFE Submersible Level Transmitter

Model No: Tek-Sub4800A-P-2-42-05-P-14	Range: 5.7 psi
Output: 4-20 mA	Power: 12 to 36 VDC
Accuracy: $\pm 0.5\%$ FS	SN:

## 2 Product Description

This section covers the reference and specification data, as well as the ordering information.

### 2.1 Principle of Operation

Tek-Sub 4800A is a PTFE Submersible Level sensor based on hydrostatic pressure measurement. This transmitter measures the level or filling height in a tank in accordance with the following principle: A liquid generates, through its specific gravity and the force of gravity, a weight force which increases with the filling height. This weight force, increasing proportionally with the filling height, is called the liquid column. The Tek-Sub 4800A measures the height-dependent weight force of this liquid column, as a hydrostatic pressure. From the measured hydrostatic pressure and the density of the product, one can calculate the filling height of the vessel.

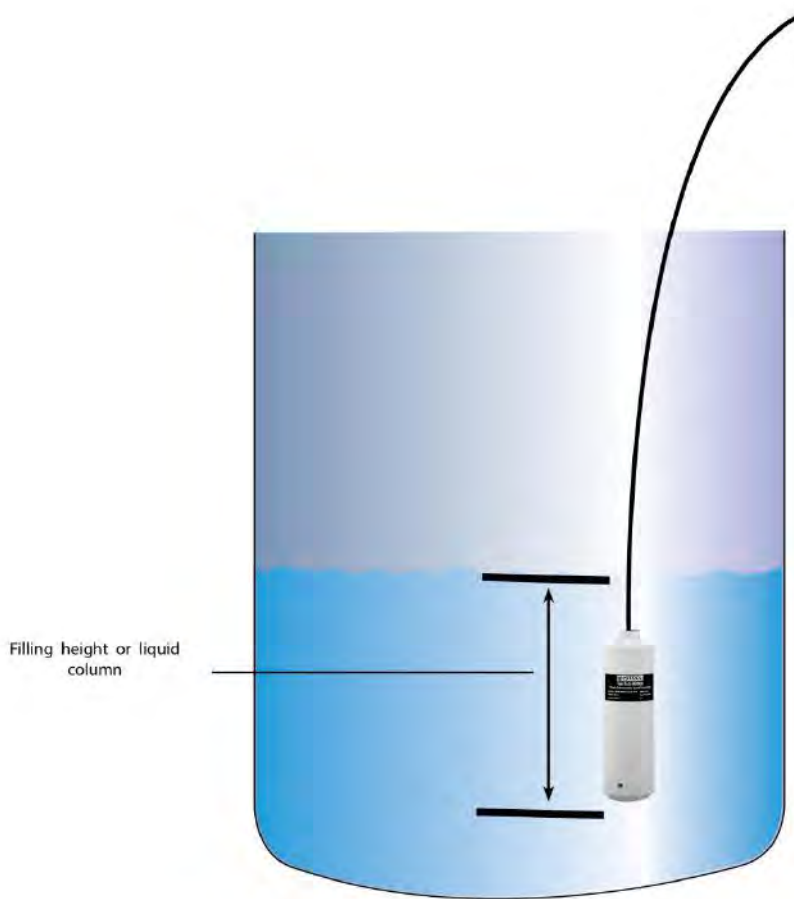

## 2.2 Technical Specification

Pressure Range	2.8 psig to 15 psig (2 mH <sub>2</sub> O to 10.5 mH <sub>2</sub> O)
Pressure Type	Gauge
Over pressure	150% FS
Accuracy	±0.25% FS(typ), ±0.5% FS(max.)
Temperature coefficient-zero	±0.02% FS/°C (typ), ±0.03% FS/°C (max.)
Temperature coefficient-span	±0.02% FS/°C (typ), ±0.03% FS/°C (max.)
Long term stability	±0.2% FS/year (typ), ±0.3% FS/year (max.)
Output signal	4 to 20mA, RS485, 0.5 to 4.5 VDC
Power supply	12 to 36 VDC, 15 to 36 VDC, 5 VDC
Load resistance(RL)	For current output: $RL \leq (V_s - 15) / 0.02 \Omega$
	For voltage output: $RL \geq 10 k\Omega$
Maximum current consumption	4 to 20 mA: 22.8 mA
	0.5 to 4.5 VDC: 2mA
	RS485: 6mA
Response time	10 ms
Vibration	10G (20-2000 Hz)
Shock	100G (10 ms)
Insulation resistance	100 MΩ/50 VDC
Compensated temperature range	PTFE: 32 °F to 140 °F (0 °C to 60 °C)
Operating temperature range	PTFE: -20 °F to 160 °F (-29 °C to 71 °C)
Storage temperature range	-40 °F to 257 °F (-40 °C to 125 °C)
Maximum specific gravity	2.2
Housing	PTFE
Cable	PTFE or Polyurethane
Diaphragm	Ceramic (Al <sub>2</sub> O <sub>3</sub> , 96%)
O-ring	FKM fluorine rubber
Protection	IP68
Net weight	0.91 lb



## 2.3 Dimensional Drawings

RS485 model

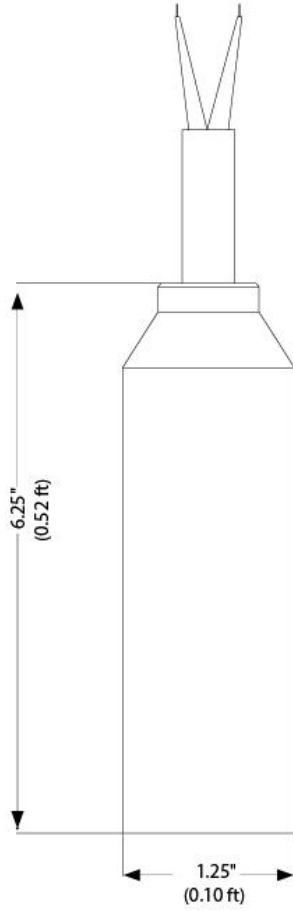

4 to 20 mA and 0.5 to 4.5 VDC models

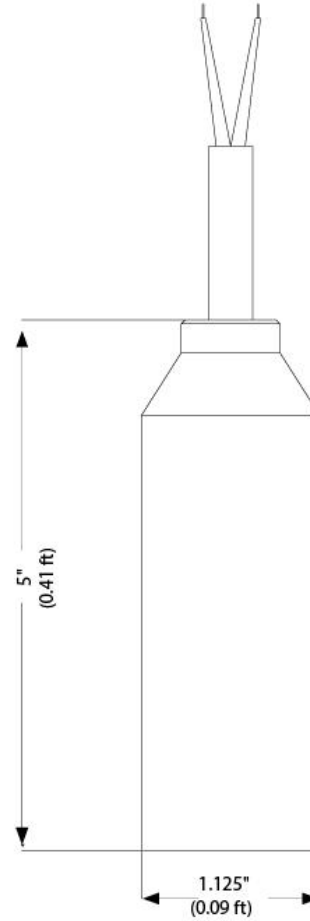

## 2.4 Model Chart

### PTFE Submersible Level Transmitter Model Chart

<b>Example</b>	Tek-Sub 4800A	T	2	42	05	T7	Tek-Sub 4800A-T-2-42-05-T7
<b>Series</b>	Tek-Sub 4800A						PTFE Submersible Level Transmitter
<b>Wetted Materials</b>		T					PTFE, Viton, and Ceramic Wetted Materials
<b>Range</b>			1 2 3 4				2.8 psig ( 2 mH <sub>2</sub> O) 5.7 psig (4 mH <sub>2</sub> O) 10 psig ( 7 mH <sub>2</sub> O) 15 psig (10.5 mH <sub>2</sub> O)
<b>Output</b>				42 45 49			4-20 mA 0.5-4.5 VDC RS485
<b>Accuracy</b>					05		0.5% FS
<b>Cable Type and Length</b>						T7 T14 T34 P7 P14 P34	20 ft. of PTFE Cable 40 ft. of PTFE Cable 100 ft. of PTFE Cable 20 ft. of Polyurethane Cable 40 ft. of Polyurethane Cable 100 ft. of Polyurethane Cable

## 3 Installation

This section covers instructions on installation and commissioning. Installation of the device must be carried out by trained, qualified specialists authorized to perform such works.



### CAUTION

- All installation must comply with local installation requirements and local electrical code.
- Do not supply the power while installing the transmitter.
- During installation and operation, connect the reference tube with the atmosphere.
- Prevent mud and sand from piling up in the reference tube. Otherwise, the transmitter would be damaged.

### 3.1 Considerations to be taken before Installation

Before installation make sure that:

- The static pressure produced by the liquid at the installation site does not exceed the transmitter FS range.
- The measuring liquid is compatible with the transmitter's construction material.
- The measuring liquid does not block the holes on the protection cap.

### 3.2 Installation Methods

- a. The installation direction of transmitter is vertically down.
- b. In the water flow condition, the surface of the transmitter should be in parallel with the direction of the water flow.

#### 3.2.1 Installation in the Static Water

- a. Fig 1 shows the installation method used in case of static water

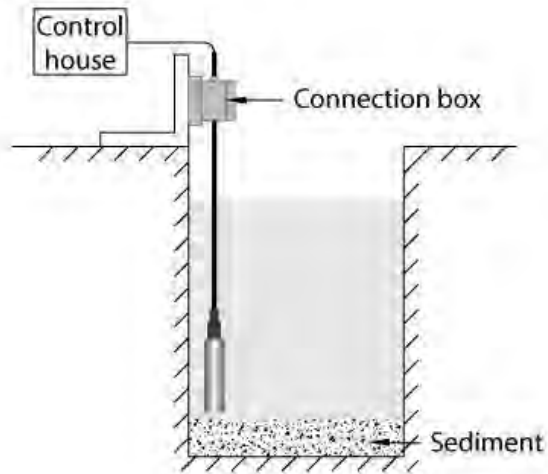

Fig. 1

- b. While pumping the liquid, the transmitter either should not be installed in the tank or it should be protected by steel tube as shown in Fig 2.

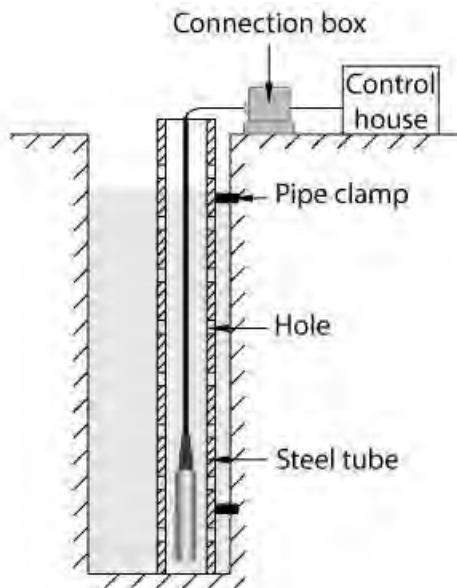

Fig. 2

3.2.2 Installation in an Open Channel (eg. Reservoir Area, River Channel)

a. Method One: Insert a steel tube in the water channel (Fig 3).

By providing the holes in a thick steel tube walls at different heights, the influence of the water pressure on the transmitter is eliminated and the waves are dampened.

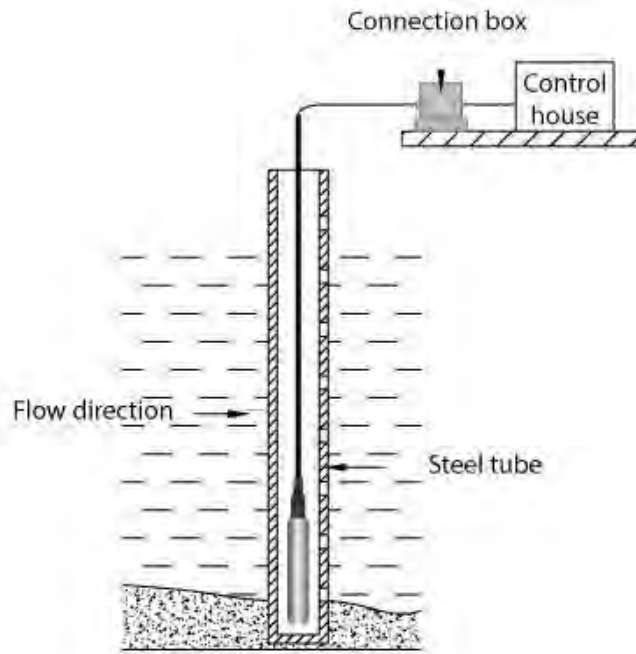

Fig. 3

b. Method Two: Superficial burying is done in the sand and stone channel (Fig 4).

This method not only eliminates pressure of the water flow and wave influence, but also filters the sand and mud particles.

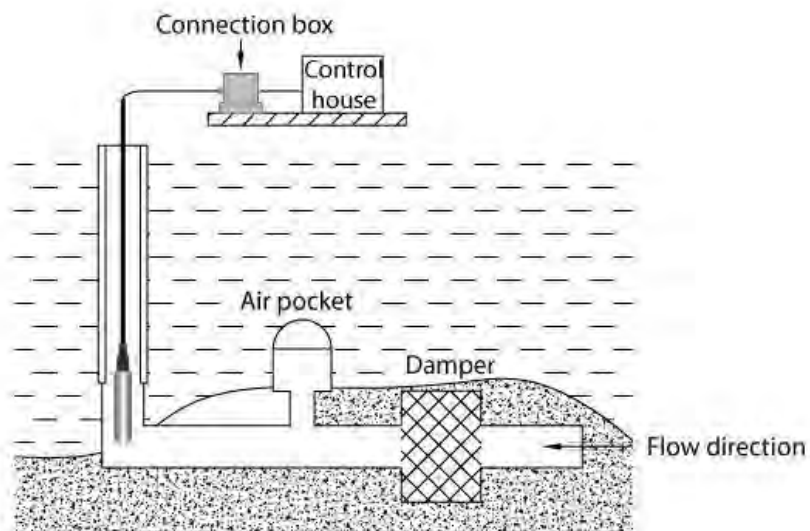

Fig. 4

## 4 Electrical Connections

This section provides the general information on the electrical connections of Tek-Sub 4800A PTFE Submersible Level Transmitter.

- RS485 Output
  - Power+: Red
  - Power-: Green
  - RS485 A+: Yellow
  - RS485 B+: Blue

- 4-20 mA Output

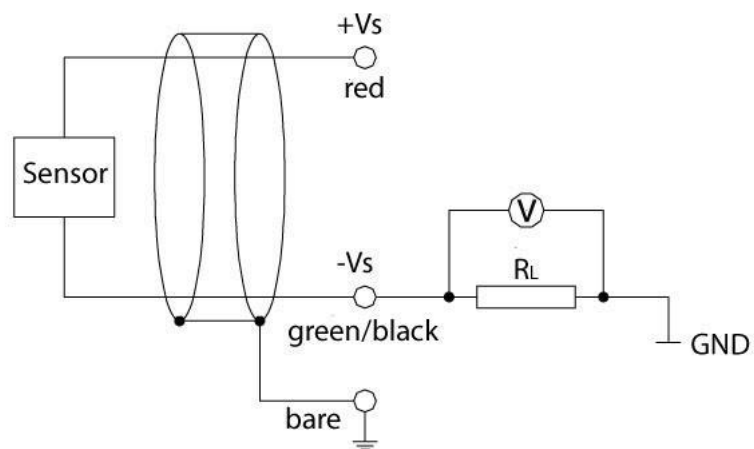

## 5 Operation

This section covers operation techniques and guidelines.

- Tek-Sub 4800A can be operated without any adjustment required.
- Make sure that the installation and electrical connection are done properly before operation.
- Connect the excitation and operate.
- The transmitter connected with the excitation works at once, but for reliable output signal wait for atleast 30 minutes.

## 6 Maintenance

This section covers maintenance techniques and guidelines.

Tek-Sub 4800A level transmitter does not require to be maintained regularly, but following points must be observed for better operation and reliability.

- Check whether the wire connection is reliable or not
- Check whether the cable is damaged or not
- Clean the protection cap and diaphragm space regularly
- Do not pull the cables violently or poke the diaphragm with metal objects.

## 7 Troubleshooting

This section provides troubleshooting techniques for most common operating problems.

If there are following errors like,

- No output given
- Output is too little
- Output is too large
- Output is unreliable

Then,

- Check whether the installation and wiring connection are done according to the instruction manual.
- Check whether the excitation provided is correct or not.
- Check whether the reference tube is unobstructed or not.

If error persists, contact Tek-Trol representative immediately.