

## High-Accuracy Non-Contact Measuring Sensors LASER SCAN MICROMETER

Combines high-rate scanning with highly accurate measurement

SENSOR SYSTEMS



# Laser Scan Micrometers

High scanning rate (3200 scans/sec) and high accuracy, non-contact measuring systems, the laser scan micrometer (LSM) inspects small, fragile workpieces at a high temperature, even while in motion or vibrating.



## FEATURES

### 0.005mm-diameter ultra-fine wires to 160mm-diameter cylinders can be measured: Seamless measurement range models

A rich assortment of models for diverse measuring applications. The LSM-500S can measure ultra-fine wires as thin as 0.005mm in diameter to a resolution of 0.00001mm, and the LSM-516S can measure cylindrical workpieces with a diameter as large as 160mm. The LSM-9506 benchtop model combines a display section and measurement section in a single unit.

### Ultra-high scanning rate of 3200 scans/sec

The incorporation of a 16-face polygonal mirror and a high-precision motor now makes scanning at 3200 scans per second possible. This formidable capability is ideal, for example, for taking measurements on high-speed production lines or on vibrating workpieces.

### Certified accuracy over entire measurement range

The specified accuracy over the entire measurement range is certified by the "Traceability System to the International Standard" which Mitutoyo, as a leading manufacturer of precision measurement tools and instruments, has established within its business practices.

### Improved resistance to IP64-level environments

The measuring unit has been extensively developed to resist rough measurement environments. As a result, for example, it can operate at an ambient temperature of 45°C. (IP64-level resistance is not guaranteed for the display unit and the LSM-9506.)

### DIN-size compact panel-mounted display unit (LSM-5200)

The LSM-5200 display unit is a compact DIN size, allowing it to be mounted in a panel so as to be suitable for mounting in a rack, etc., for use on production lines.

### Standard I/O output, analog output and RS-232C output interfaces. Wireless capable

The LSM-5200/6200/6900 has a standard I/O and analog output interface to connect it to an operation controller or PLC used on a production line. Also, every model has a standard RS-232C interface for connection to personal computers or printers. Capable of using U-wave wireless system using optional accessories.

### QUICKTOOL

**Free Quicktool\*** software simplifies the setup and operation of the LSM-6200/9506/6900.

This program can be downloaded from <http://www.mitutoyo.jp>

\*For use with customer-supplied PC and RS-232C cable

## PRINCIPLE

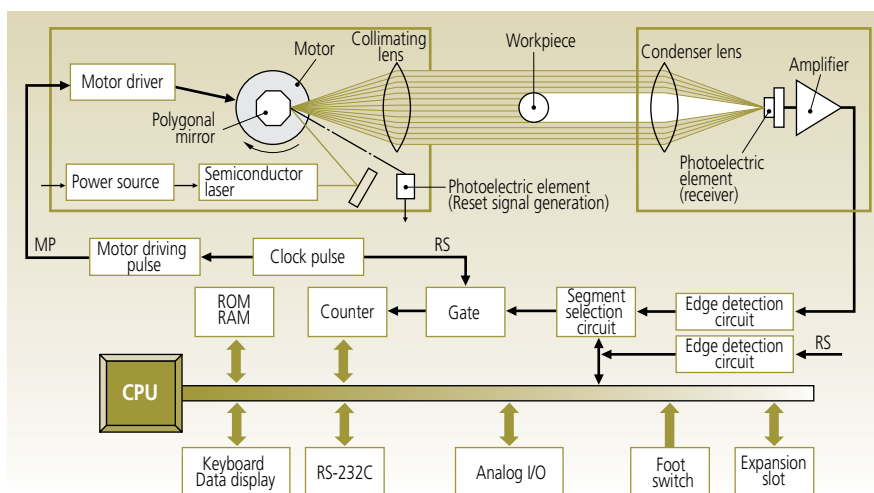

A laser beam is directed at a polygonal mirror rotating at high speed in exact synchronism with highly stable pulses from the system clock. The reflected beam is rotating clockwise as it sweeps across the input surface of a collimating lens but changes direction to be always horizontal after the lens' exit surface as it moves, or scans, downward. This horizontal beam enters the measuring space and, with no workpiece present, reaches a receiver via a condensing lens to produce an output signal. When a simple workpiece (a cylinder, for example) is put into the measuring space the beam will be interrupted for a time during its sweep and this time, as indicated by clock pulses occurring while the receiver signal is absent, is proportional to the workpiece dimension in the downward direction.

Each transition between the receiver detecting the beam and then not detecting the beam, or vice versa, is called an edge and marks the start and/or end of measuring sections called segments, so that the differences in position of these edges define the length of each segment. The edges and segments generated by a workpiece are numbered sequentially by the instrument and are used when writing programs to extract the required dimensional data.

## INDEX

	Pages
Applications	4
Laser Scan Micrometer Models	6
<b>Measuring Unit</b>	
LSM-6902H/6900 Ultra-High Accuracy Measuring Unit	8
LSM-500S Ultra-Fine Wire Measuring Unit	10
LSM-501S Fine Wire Measuring Unit	12
LSM-503S Standard Measuring Unit	14
LSM-506S Wide Range Measuring Unit	16
LSM-512S Ultra-Wide Range Measuring Unit	18
LSM-516S Ultra-Wide Range Measuring Unit	20
LSM-9506 Benchtop with Display Unit	22
<b>Optional Accessories for Measuring Unit</b>	
Calibration Gage Sets	23
Extension Signal Cables	23
Extension Relay Cables	23
Workstage	23
Wire Guiding Pulleys	23
Air-screen System	23
Adjustable Workstages	24

	Pages
<b>Display Unit</b>	
LSM-5200 Compact (Panel-mount) Display Unit	28
LSM-6200 Multi-function Display Unit	29
LSM-5200/6200/6900/9506 Functions	30
LSM-5200/6200/6900/9506 Data I/O Specifications	32
<b>Optional Accessories for Display Unit</b>	
LSMPAK	34
BCD Interface Unit	34
Digimatic Code-out Unit	35
Dual-type Add-on Unit	35
2nd I/O-Analog Interface Unit	36
BCD/2nd I/O-Analog Interface Cable	37
Thermal Printer	37
Footswitch	37
Glossary	38
Precautions	39

# Applications

## Measurement Examples

In-line glass fiber or fine wire diameter

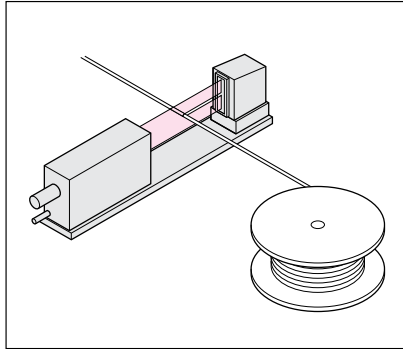

Outer diameter of opaque or transparent cylinders

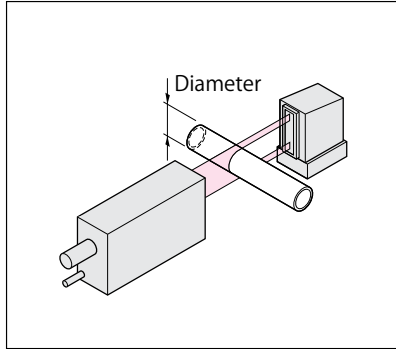

Outer diameter and roundness of cylinder

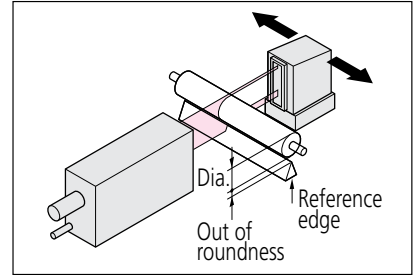

X- and Y-axis electric cables and fibers

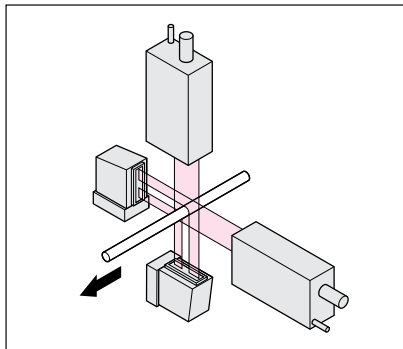

Thickness of film and sheet

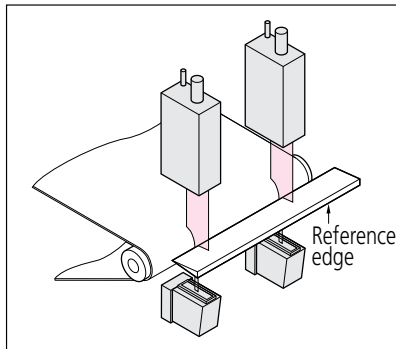

Spacing of IC chip leads

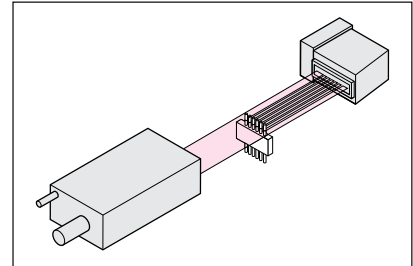

Film sheet thickness

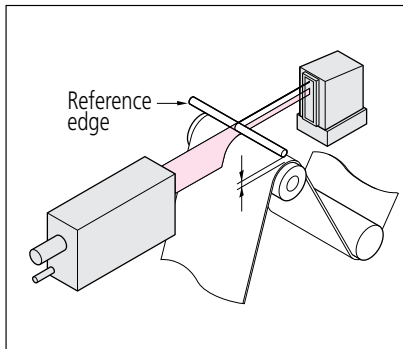

Disk head movement

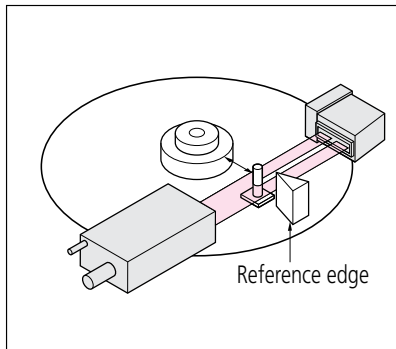

Gap between rollers

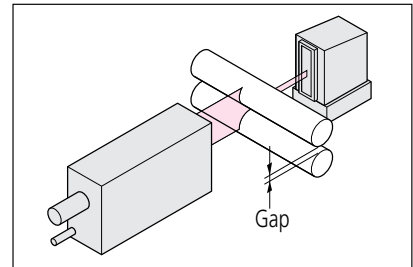

Taper and form

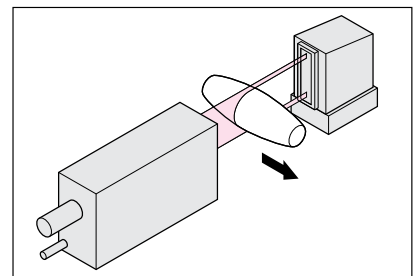

Tape width

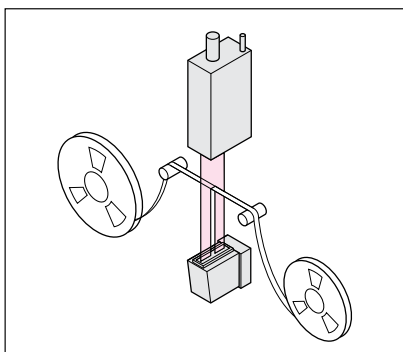

Outer diameter of optical connector and ferrule

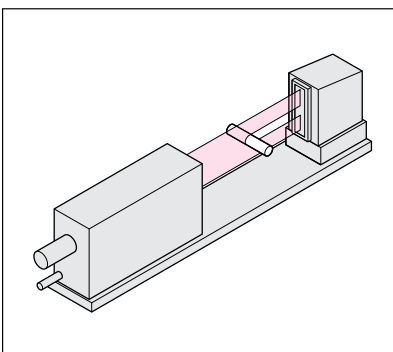

Dual system for measuring a large outside diameter

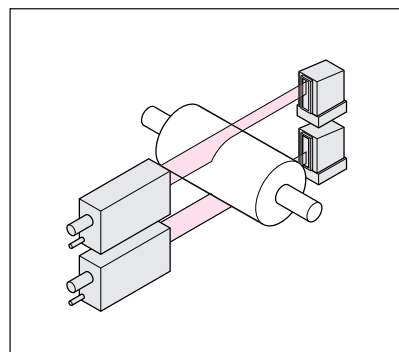

## Optimal for Inspecting the Outside Diameter of Pin Gages or Plug Gages

The use of world-class laser scan micrometer LSM-6902H/6900, along with an adjustable workstage, allows high-accuracy measurement inspection of the outside diameter of pin gages or plug gages. This LSM is also capable of data output to an external device such as a personal computer from the display unit.

(Measurement data can be stored easily in EXCEL by using a Mitutoyo input tool.)

### Major Specifications

**Measuring range:** 0.1mm to 25.0mm in diameter

**Resolution:** 0.01 $\mu$ m

**Linearity:** from  $\pm 0.3\mu$ m to  $\pm 0.5\mu$ m\*

**Repeatability:**  $\pm 0.05\mu$ m

\* depending on  $\Delta$  from calibration size

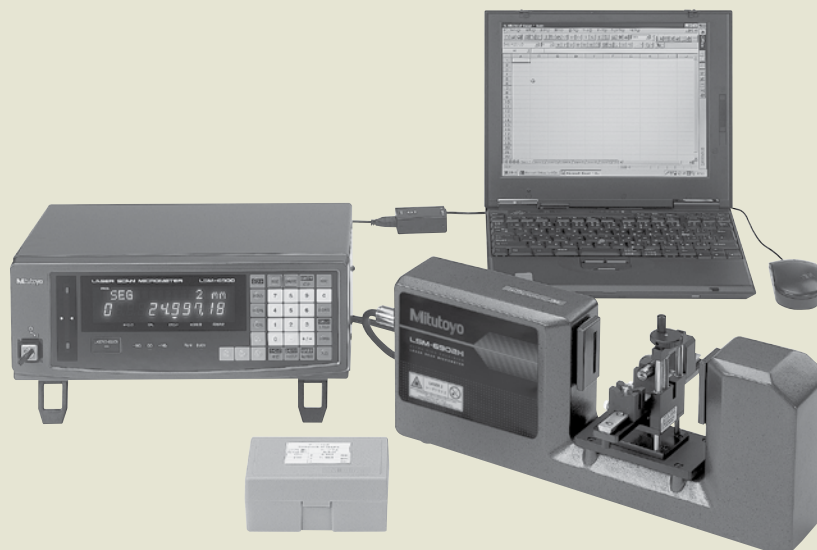
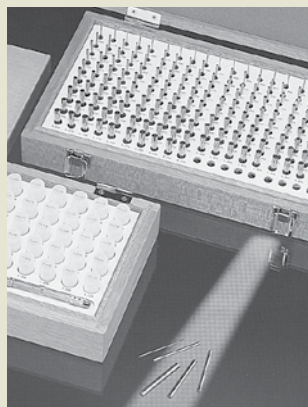
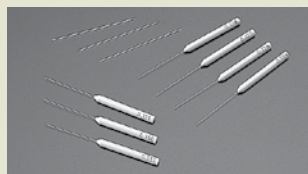

# MODELS OF LASER SCAN MICROMETERS

## MEASURING UNITS

Measuring range	Model	Page
0.005 - 2mm (.0002" - .08")	<b>LSM-500S</b> 	10
0.05 - 10mm (.002" - .4") FDA Class II	<b>LSM-501S</b> 	12
0.3 - 30mm (.012" - 1.18")	<b>LSM-503S</b> 	14
1 - 60mm (.04" - 2.36")	<b>LSM-506S</b> 	16
1 - 120mm (.04" - 4.72")	<b>LSM-512S</b> 	18
1 - 160mm (.04" - 6.30")	<b>LSM-516S</b> 	20

## MEASURING UNIT (Factory-set package)

Measuring range	Model	Page
0.1 - 25mm (.004" - 1.0")	<b>LSM-6902H/6900</b> 	8

## MEASURING UNIT WITH INTEGRATED DISPLAY

Measuring range	Model	Page
0.5 - 60mm (.02" - 2.36")	<b>LSM-9506</b>  <p>Measuring unit / integrated-display model for benchtop use only</p>	22

## DISPLAY UNITS

Type	Model	Page
Multi-function (Power Supply 100V - 240V AC)	<b>LSM-6200</b> 	29
Compact (Power Supply +24V DC)	<b>LSM-5200</b> 	28

# LSM-6902H/6900

## Ultra-High Accuracy Measuring

- Suitable for high-accuracy applications such as pin and plug gage calibration.
- Wide measuring range of  $\varnothing 0.1\text{mm}$  to  $\varnothing 25\text{mm}$  (.004" - 1")
- Provides ultra-high accuracy with a linearity of  $\pm 0.5\mu\text{m}$  ( $\pm 20$  pinch) over the entire measurement range and  $\pm (0.3+0.1\Delta D)\mu\text{m}$  in the narrow range.
- Ultra-high repeatability down to  $\pm 0.03\mu\text{m}$  ( $\pm 1.2$  pinch)

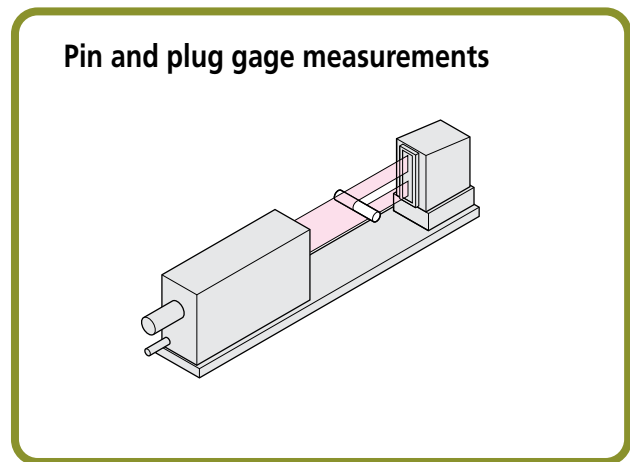
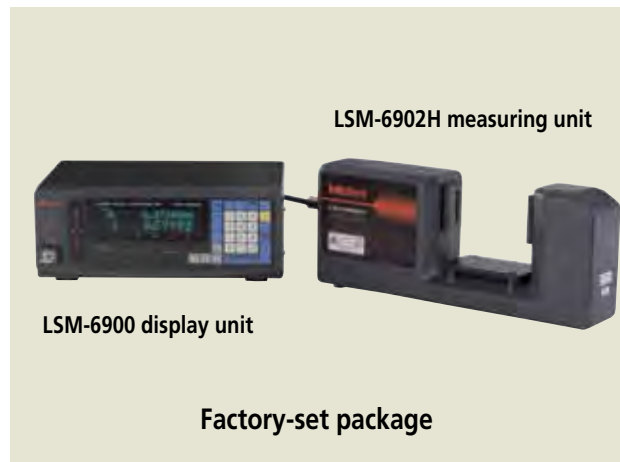

### SPECIFICATIONS

Model	LSM-6902H/6900	
	120V AC	544-499-1A
Acceptable standard of laser	IEC (FDA: <b>544-499-1A</b> )	
Measuring range	0.1 - 25mm (.004" - 1.0")	
Resolution (selectable)	0.00001 - 0.01mm (.000001" - .0005")	
Repeatability* <sup>1</sup>	+/-0.045 $\mu\text{m}$ (dia. 25mm), +/-0.03 $\mu\text{m}$ (dia. 10mm)	
Linearity at 20°C* <sup>2</sup>	Entire range	$\pm 0.5\mu\text{m}$ ( $\pm 20$ pinch)
	Narrow range	$\pm (0.3+0.1\Delta D)\mu\text{m}$ * <sup>5</sup>
Positional error* <sup>3</sup>	$\pm 0.5\mu\text{m}$ ( $\pm 20$ pinch)	
Measuring region* <sup>4</sup>	+/- 1.5 x 25 (+/-0.06x1.0")	
Scanning rate	3200/sec	
Laser wavelength	650nm, Visible* <sup>6</sup>	
Laser scanning speed	226m/sec (8898"/sec)	
Operating temperature	0°C - 40°C	
Operating humidity	35 - 85% RH (with no condensation)	
Mass	Measuring unit: 6.0kg (13.2lbs.), Signal cable: 0.5kg (1.1lbs.)	

<Measuring unit>	
Type	inch/mm
Display	16-digit fluorescent tube (for measurement) & 11-digit fluorescent tube (sub display)
Segment designation	Seg.1 to Seg.7 (Seg.1 - Seg.3 for transparent objects)
Edge designation	1 to 255 edges can be detected
Averaging times	Arithmetical average: per 2 to 2048, moving average: per 32 to 2048
Go/no-go judgment	Nominal value $\pm$ tolerance setting, upper & lower limits setting, multi-limit setting
Measurement mode	Waiting, single measurement, continuous measurement
Statistical calculation	Maximum measurement (MAX), minimum measurement (MIN), mean, range (MAX-MIN), standard deviation ( $\sigma$ )
Power supply	120V AC $\pm 10\%$ , 60Hz, 40VA
Data output (as standard)	Via RS-232C and I/O-Analog interfaces
Functions	(See pages 16 and 17.)
Operating temperature	0°C - 40°C
Operating humidity	35 - 85% RH (with no condensation)
Mass	5kg (11lbs.)

\*1: Determined by the value for  $\pm 2\sigma$  at the measurement of  $\varnothing 25\text{mm}$  workpiece with 1.28sec. interval (1024-time average).  
 \*2: At the center of the measuring region.  
 \*3: An error due to workpiece shift either in the optical axis direction or in the scanning direction.  
 \*4: The area given by "measuring range on the optical axis" x "measuring range in the scanning direction."  
 \*5:  $\Delta D$ =Difference in diameter between the master gage and workpiece in mm.  
 \*6: FDA Class I/IEC Class 2 semiconductor laser for scanning (Maximum power: 1.0mW)



Optional accessories to connect to QuickTool (data can be saved as XLS file & later opened in Excel) or SPC software that requires RS-232C/virtual COM data:

- 12AAA807** RS-232C output cable (null modem cable, can also be used to communicate with a PLC if the PLC has 9-pin RS-232C input port)
- 64AAB532** Serial to USB adapter (RS-232C cable or equivalent adapters are also needed)

Optional accessories for sending data directly to Excel, etc. (Digimatic output, max resolution possible: 10μinch):

- 02AGC840** Digimatic Output Card (this card is not needed if using LSM-9506)
- 06AFM380D** USB Input Tool (virtual keyboard format)

Other output options are available, including wireless. Contact us for details.

### Dimensions

Unit: mm

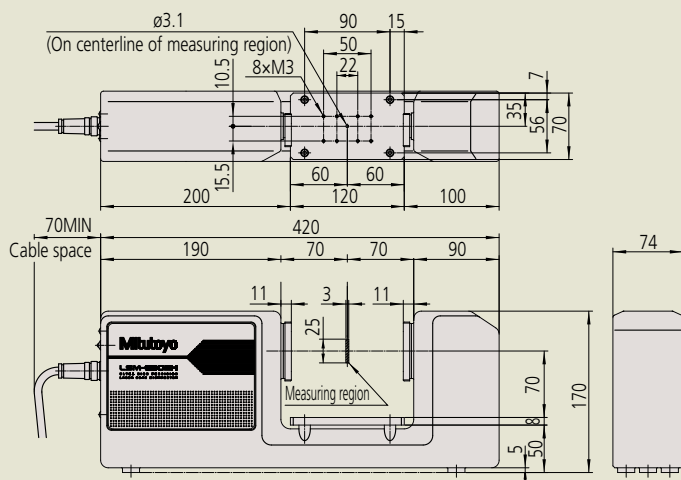

LSM-6902H measuring unit

Power Supply  
120V

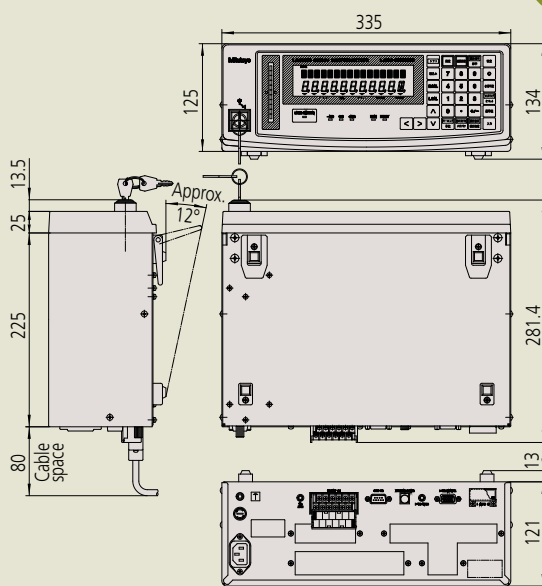

LSM-6900 display unit

### OPTIONAL ACCESSORIES

#### 02AGD180

Calibration gage set (ø1mm, ø25mm)



#### 02AGD270

Workstage



#### 02AGD280

Adjustable workstage

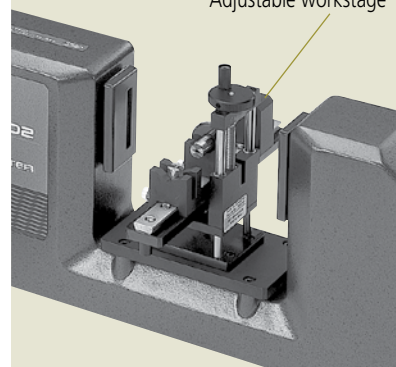

# LSM-500S

## Ultra-Fine Wire Measuring

- Permits measurements starting from  $\phi 5\mu\text{m}$
- Provides ultra-high accuracy with a linearity of  $\pm 0.3\mu\text{m}$  over the entire measurement range (5 $\mu\text{m}$  to 2mm).
- Ultra-high repeatability of  $\pm 0.03\mu\text{m}$

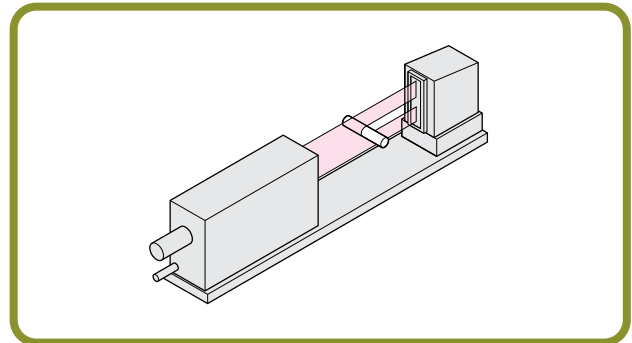
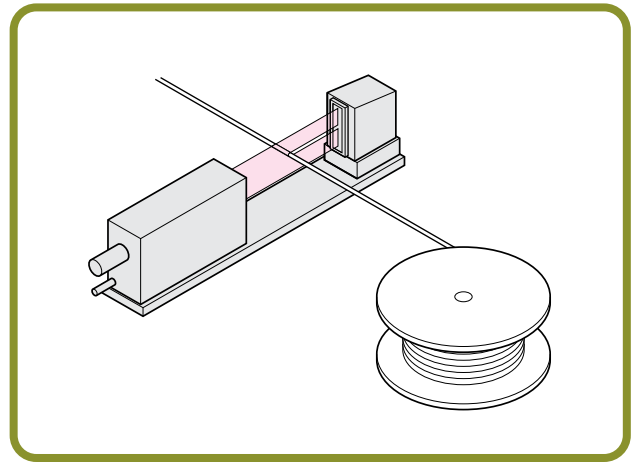

### SPECIFICATIONS

<b>Model</b>	<b>LSM-500S</b>
<b>Order No.</b> (Laser only)	<b>544-532</b>
<b>Package No.</b> (with LSM 6200 Display)	<b>64PKA117</b>
Acceptable standard of laser	IEC, FDA
Measuring range*1	0.005 - 2mm (.0002" - .08")
Resolution (selectable)	0.00001 - 0.01mm (.000001" - .0005")
Repeatability*2	$\pm 0.03\mu\text{m}$ ( $\pm 1.1\mu\text{inch}$ )
Linearity at 20°C*3	$\pm 0.3\mu\text{m}$ ( $\pm 12\mu\text{inch}$ )
Positional error*4	$\pm 0.4\mu\text{m}$ ( $\pm 16\mu\text{inch}$ )
Measuring region*5	1x2mm (.04" x .08")
Scanning rate	3200 scans/s
Laser wavelength	650nm, Visible*6
Laser scanning speed	76m/s (3000"/s)
Operating temperature	0°C - 40°C
Operating humidity	35 - 85% RH (with no condensation)
Water/Dust protection grade	Conforming to IP64*7
Mass	Measuring unit: 1.0kg (2.2lbs.), Signal cable: 0.5kg (1.1lbs.)

\*1: If a workpiece is transparent or if the dual-type add-on unit that is an optional accessory for the **LSM-6200** display unit is used, measurement range will be set to between 0.05mm (.002") to 2mm (.08"). In addition, if the edge measurement is selected for 1 to 255 edges or if the automatic workpiece detecting function is on, measuring range will be set to between 0.1mm (.004") to 2mm (.08").

\*2: Determined by the value for  $\pm 2\sigma$  at the measurement of  $\phi 2\text{mm}$  workpiece with 0.32sec. interval (1024-time average).

\*3: At the center of the measuring region.

\*4: An error due to workpiece shift either in the optical axis direction or in the scanning direction.

\*5: The area given by "measuring range on the optical axis" x "measuring range in the scanning direction."

\*6: FDA Class II/IEC Class 2 semiconductor laser for scanning (Maximum power: 1.3mW)

\*7: The protection level provided for the interior. If the workpiece or glass of the measuring unit window is soiled by water or dust, the unit may malfunction.



Dimensions

Unit: mm (inch)

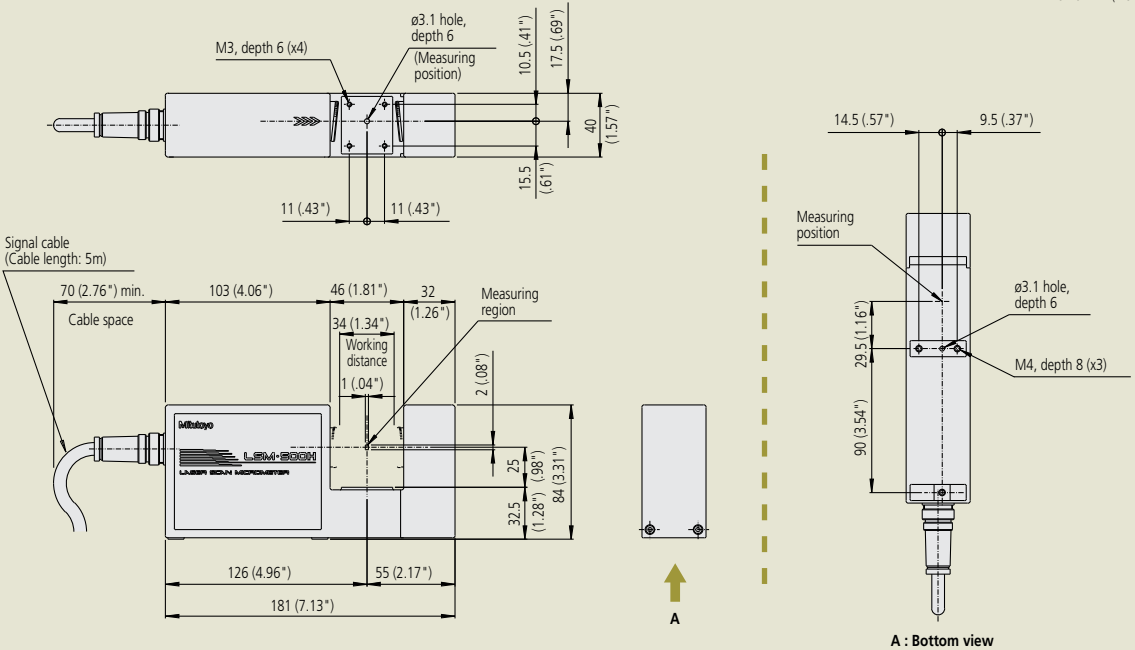

OPTIONAL ACCESSORIES

**02AGD110**  
Calibration gage set ( $\phi 0.1\text{mm}$ ,  $\phi 2.0\text{mm}$ )



**02AGD200**  
Wire guiding pulley

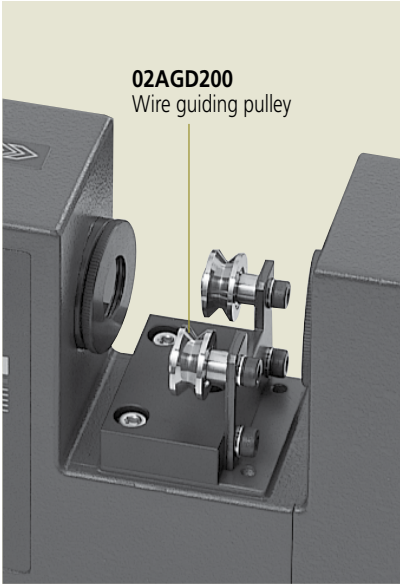

**02AGD220**  
Air-screen covers



**957608** Air cleaner for air-screen covers  
**02AGN780A** Extension signal cable 5m  
**02AGN780B** Extension signal cable 10m  
**02AGN780C** Extension signal cable 15m

# LSM-501S

## Fine Wire Measuring

- Provides ultra-high accuracy with a linearity of  $\pm 0.5\mu\text{m}$  over the entire measurement range (0.05mm to 10mm) and  $\pm(0.3+0.1\Delta D)\mu\text{m}$  in the narrow range.
- Ultra-high repeatability of  $\pm 0.04\mu\text{m}$

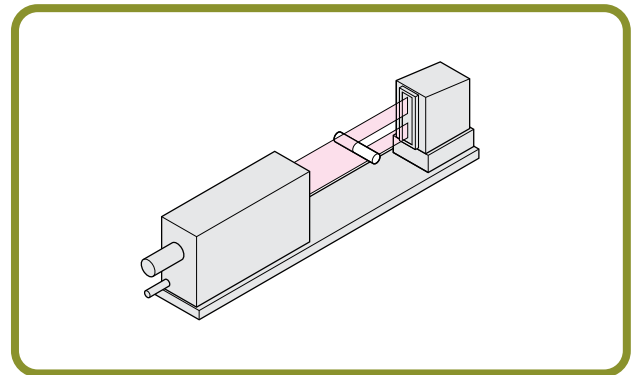
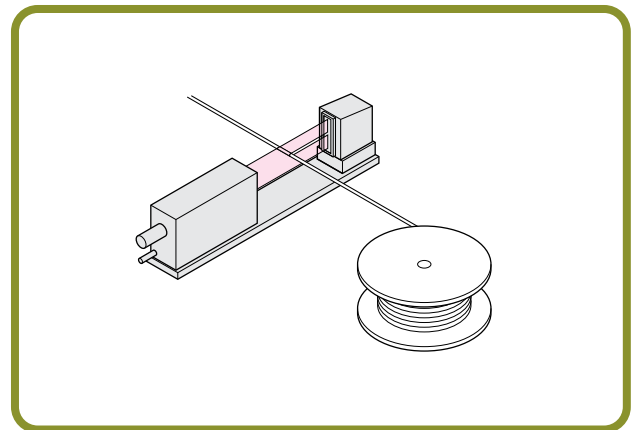

### SPECIFICATIONS

Model	LSM-501S	
Order No. (Laser only)	544-534	
Package No. (Laser w/LSM 6200 display)	64PKA118	
Acceptable standard of laser	IEC, FDA	
Measuring range	0.05 - 10mm (.002" - .4")	
Resolution (selectable)	0.00001 - 0.01mm (.000001" - .0005")	
Repeatability*1	$\pm 0.04\mu\text{m}$ ( $\pm 1.5\mu\text{inch}$ )	
Linearity at 20°C*2	Entire range	$\pm 0.5\mu\text{m}$ ( $\pm 20\mu\text{inch}$ )
	Narrow range	$\pm(0.3+0.1\Delta D)\mu\text{m}$
Positional error*3	$\pm 0.5\mu\text{m}$ ( $\pm 20\mu\text{inch}$ )	
Measuring region*4	2 x 10mm at $\phi 0.05 - 0.1\text{mm}$ (.08" x .4" at $\phi 0.002" - .004"$ ) 4 x 10mm at $\phi 0.1 - 10\text{mm}$ (.16" x .4" at $\phi 0.004" - .4"$ )	
Scanning rate	3200 scans/s	
Laser wavelength	650nm, Visible*5	
Laser scanning speed	113m/s (4450"/s)	
Operating temperature	0°C - 40°C	
Operating humidity	35 - 85% RH (with no condensation)	
Water/Dust protection grade	Conforming to IP64*6	
Mass	Emission unit: 0.7kg (1.54lbs.), Reception unit: 0.4kg (.88lbs.), Base: 0.3kg (.66lbs.), Signal cable: 0.5kg (1.1lbs.)	



LSM-6200 display unit (optional)



LSM-5200 display unit (optional)

\*1: Determined by the value for  $\pm 2\sigma$  at the measurement of  $\phi 10\text{mm}$  workpiece with 0.32sec. interval (512-time average).  
 \*2: At the center of the measuring region.  
 \*3: An error due to workpiece shift either in the optical axis direction or in the scanning direction.  
 \*4: The area given by "measuring range on the optical axis" x "measuring range in the scanning direction."  
 \*5: FDA Class II/IEC Class 2 semiconductor laser for scanning (Maximum power: 1.3mW)  
 \*6: The protection level provided for the interior. If the workpiece or glass of the measuring unit window is soiled by water or dust, the unit may malfunction.

Dimensions

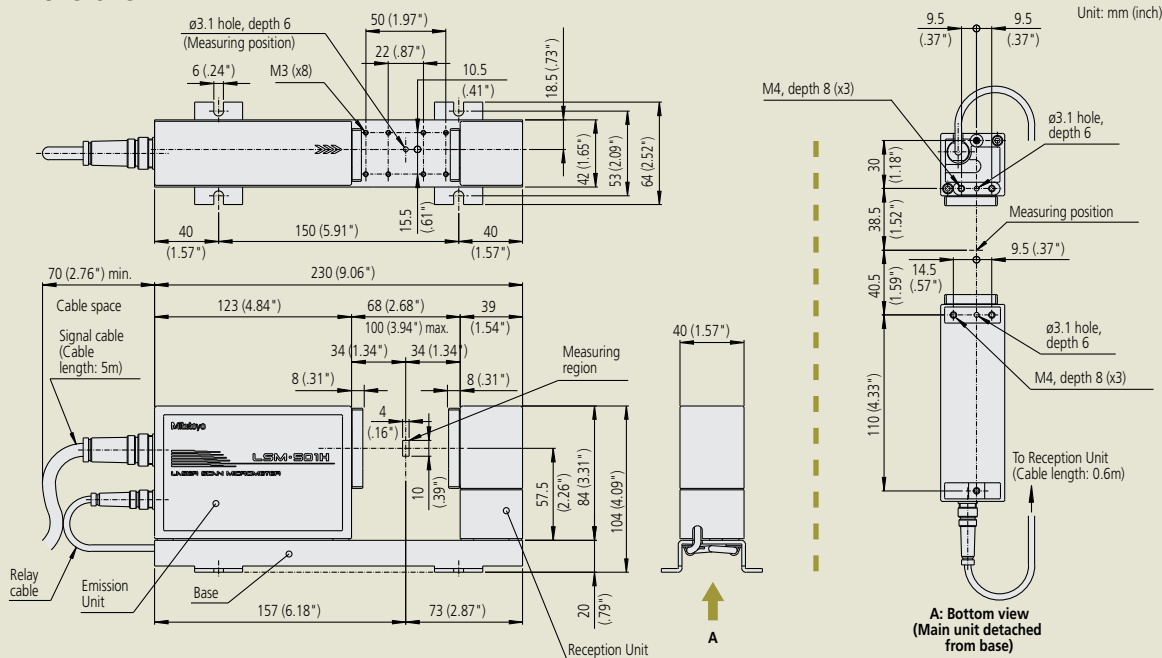

OPTIONAL ACCESSORIES

02AGD120

Calibration gage set (ø0.1mm, ø10mm)



02AGD210

Wire guiding pulley

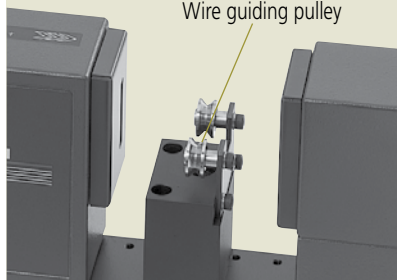

02AGD400

Adjustable workstage

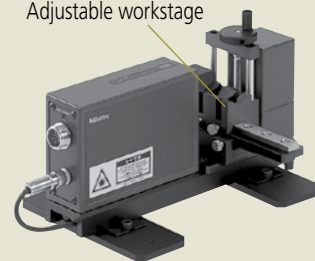

02AGD230

Air-screen covers



02AGD270

Workstage



02AGD440

Center support\*

02AGD450

Adjustable V-block\*

957608

Air cleaner for air-screen cover

02AGC150A

Extension relay cable 1m

02AGN780A

Extension signal cable 5m

02AGN780B

Extension signal cable 10m

02AGN780C

Extension signal cable 15m

\*Use with an adjustable workstage.

# LSM-503S

## Standard Measuring

- General-purpose type with a measurement range of 0.3mm to 30mm.
- Provides high accuracy with a linearity of  $\pm 1.0\mu\text{m}$  over the entire measurement range and  $\pm(0.6+0.1\Delta D)\mu\text{m}$  in the narrow range.
- Excellent repeatability of  $\pm 0.1\mu\text{m}$

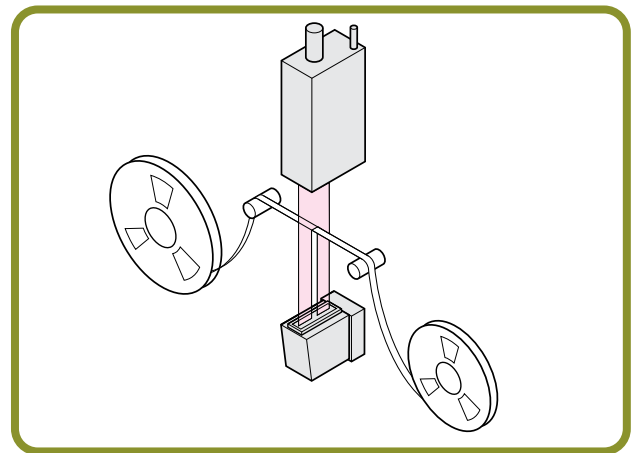
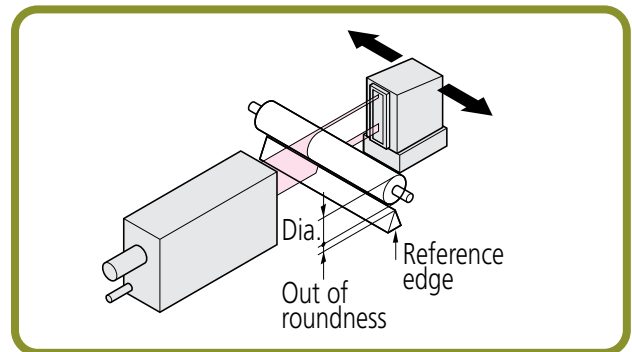

### SPECIFICATIONS

<b>Model</b>	<b>LSM-503S</b>	
<b>Order No.</b> (Laser only)	<b>544-536</b>	
<b>Package No.</b> (Laser w/LSM 6200 display)	<b>64PKA119</b>	
Acceptable standard of laser	IEC, FDA	
Measuring range	0.3 - 30mm (.012" - 1.18")	
Resolution (selectable)	0.00002 - 0.1mm (.000001" - .005")	
Repeatability*1	$\pm 0.11\mu\text{m}$ ( $\pm 3.9\mu\text{inch}$ )	
Linearity at 20°C*2	Entire range	$\pm 1.0\mu\text{m}$ ( $\pm 40\mu\text{inch}$ )
	Narrow range	$\pm(0.6+0.1\Delta D)\mu\text{m}$
Positional error*3	$\pm 1.5\mu\text{m}$ ( $\pm 60\mu\text{inch}$ )	
Measuring region*4	10 x 30mm (.4" x 1.18")	
Scanning rate	3200 scans/s	
Laser wavelength	650nm, Visible*5	
Laser scanning speed	226m/s (8900"/s)	
Operating temperature	0°C - 40°C	
Operating humidity	35 - 85% RH (with no condensation)	
Water/Dust protection grade	Conforming to IP64*6	
Mass	Emission unit: 1.1kg (2.42lbs.), Reception unit: 0.6kg (1.32lbs.), Base: 0.5kg (1.1lbs.), Signal cable: 0.5kg (1.1lbs.)	

\*1: Determined by the value for  $\pm 2\sigma$  at the measurement of  $\phi 10\text{mm}$  workpiece with 0.32sec. interval (512-time average).

\*2: At the center of the measuring region.

\*3: An error due to workpiece shift either in the optical axis direction or in the scanning direction.

\*4: The area given by "measuring range on the optical axis" x "measuring range in the scanning direction."

\*5: FDA Class II/IEC Class 2 semiconductor laser for scanning (Maximum power: 1.3mW)

\*6: The protection level provided for the interior. If the workpiece or glass of the measuring unit window is soiled by water or dust, the unit may malfunction.

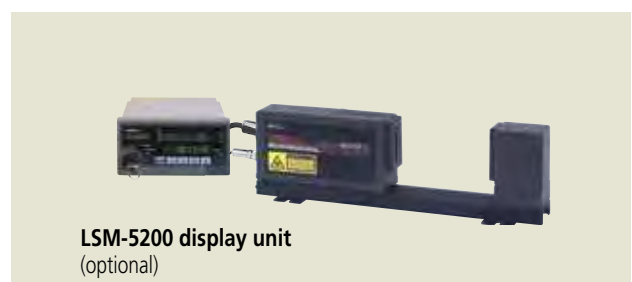

**Dimensions**

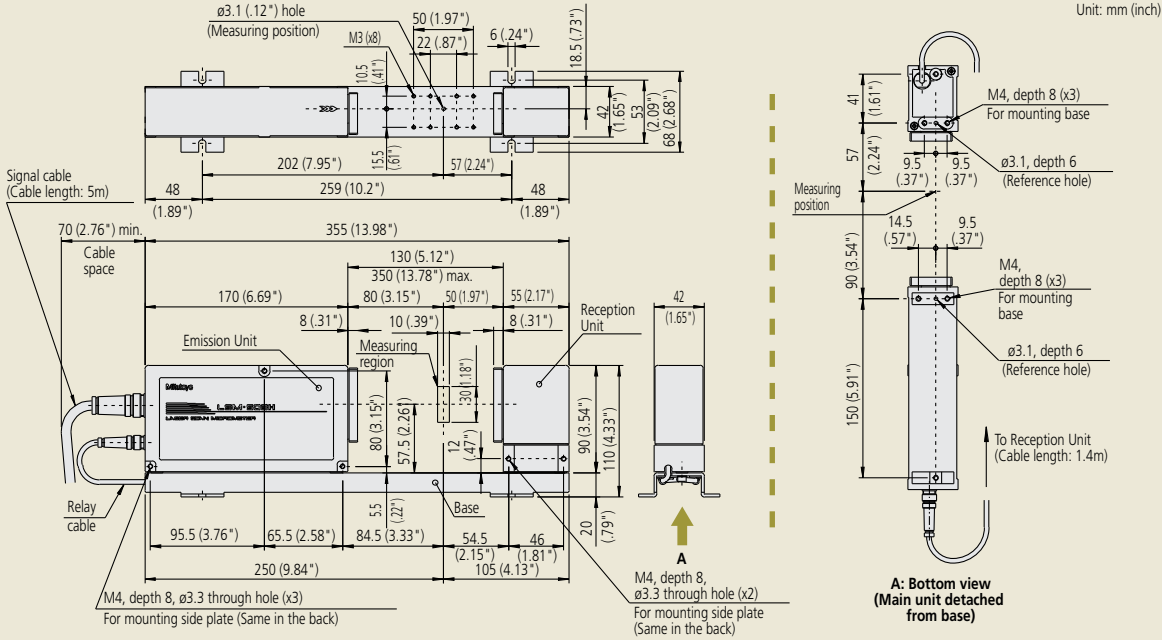

**OPTIONAL ACCESSORIES**



- 02AGD440 Center support\*
  - 02AGD450 Adjustable V-block\*
  - 957608 Air cleaner for air-screen covers
  - 02AGC150A Extension relay cable 1m
  - 02AGC150B Extension relay cable 3m
  - 02AGC150C Extension relay cable 5m
  - 02AGN780A Extension signal cable 5m
  - 02AGN780B Extension signal cable 10m
  - 02AGN780C Extension signal cable 15m
  - 02AGN780D Extension signal cable 20m
- \*Use with an adjustable workstage.

# LSM-506S

## Wide Range Measuring

- General-purpose type with a measurement range of 1mm to 60mm.
- Provides high accuracy with a linearity of  $\pm 3\mu\text{m}$  over the entire measurement range and  $\pm(1.5+0.5\Delta D)\mu\text{m}$  in the narrow range.
- Excellent repeatability of  $\pm 0.36\mu\text{m}$



### SPECIFICATIONS

<b>Model</b>	<b>LSM-506S</b>
<b>Order No.</b> (Laser only)	<b>544-538</b>
<b>Package No.</b> (Laser w/LSM 6200 display)	<b>64PKA120</b>
Acceptable standard of laser	IEC, FDA
Measuring range	1 - 60mm (.04" - 2.36")
Resolution (selectable)	0.00005 - 0.1mm (.000002" - .005")
Repeatability*1	$\pm 0.36\mu\text{m}$ ( $\pm 14\mu\text{inch}$ )
Linearity Entire range	$\pm 3.0\mu\text{m}$ ( $\pm 120\mu\text{inch}$ )
at 20°C*2	
Narrow range	$\pm(1.5+0.5\Delta D)\mu\text{m}$
Positional error*3	$\pm 4.0\mu\text{m}$ ( $\pm 160\mu\text{inch}$ )
Measuring region*4	20 x 60mm (.8" x 2.36")
Scanning rate	3200 scans/s
Laser wavelength	650nm, Visible*5
Laser scanning speed	452m/s (17800"/s)
Operating temperature	0°C - 40°C
Operating humidity	35 - 85% RH (with no condensation)
Water/Dust protection grade	Conforming to IP64*6
Mass	Emission unit: 1.4kg (3.08lbs.), Reception unit: 0.8kg (1.76lbs.), Base: 0.8kg (1.76lbs.), Signal cable: 0.5kg (1.1lbs.)

\*1: Determined by the value for  $\pm 2\sigma$  at the measurement of  $\phi 10\text{mm}$  workpiece with 0.32sec. interval (512-time average).

\*2: At the center of the measuring region.

\*3: An error due to workpiece shift either in the optical axis direction or in the scanning direction.

\*4: The area given by "measuring range on the optical axis" x "measuring range in the scanning direction."

\*5: FDA Class II/IEC Class 2 semiconductor laser for scanning (Maximum power: 1.3mW)

\*6: The protection level provided for the interior. If the workpiece or glass of the measuring unit window is soiled by water or dust, the unit may malfunction.

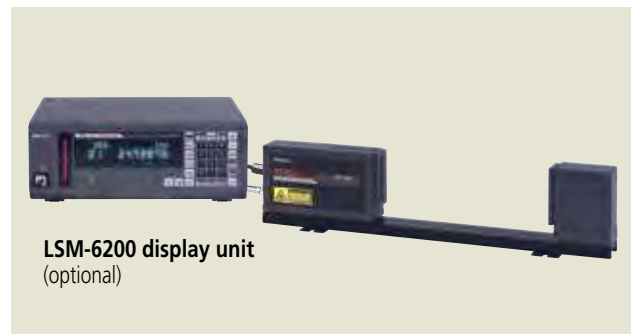
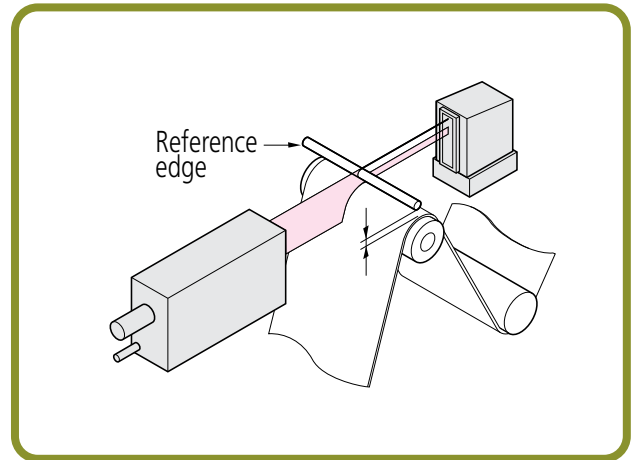
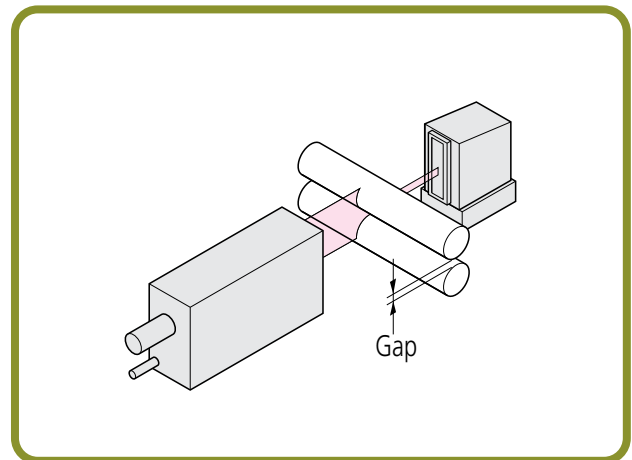



## Dimensions

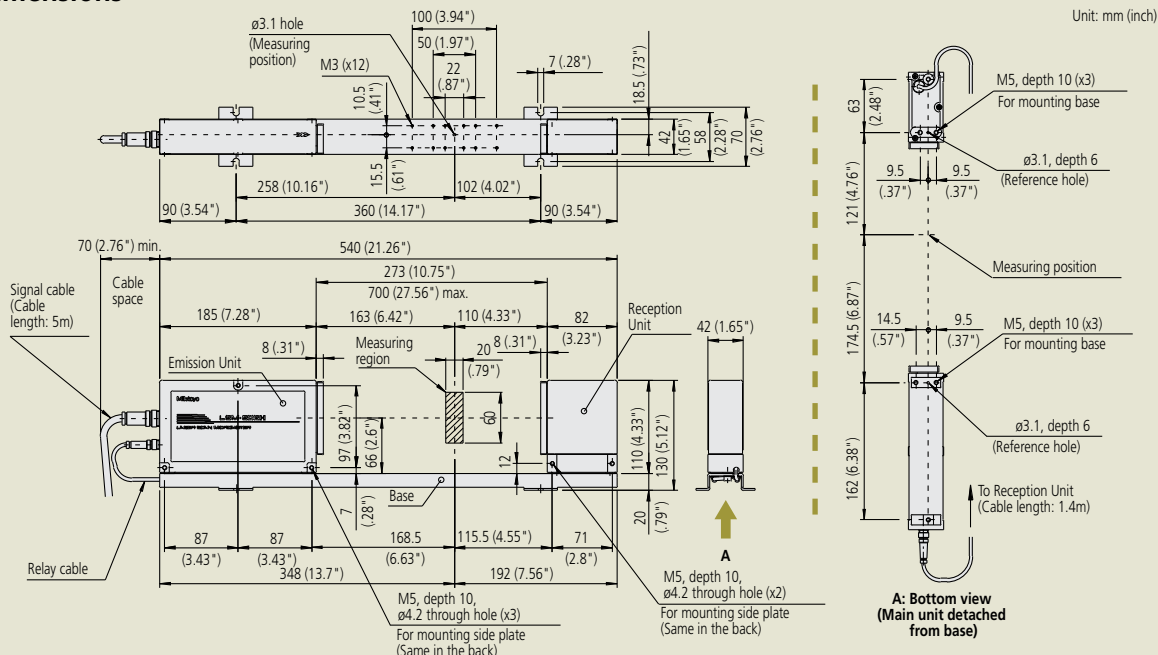

## OPTIONAL ACCESSORIES

### 02AGD140

Calibration gage set ( $\phi 1.0\text{mm}$ ,  $\phi 60\text{mm}$ )



### 02AGD520

Adjustable workstage

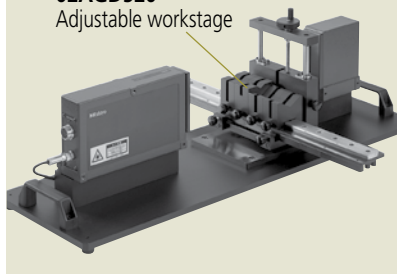

### 02AGD250

Air-screen covers

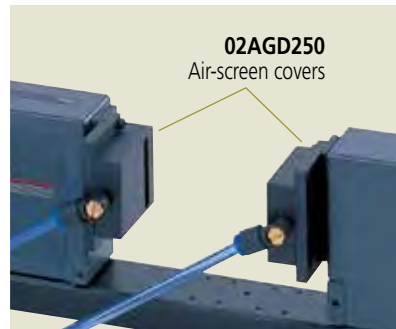

- 02AGD580 Center support\*
- 02AGD590 Adjustable V-block\*
- 02AGD250 Air-screen cover
- 957608 Air cleaner for air-screen covers
- 02AGC150A Extension relay cable 1m
- 02AGC150B Extension relay cable 3m
- 02AGC150C Extension relay cable 5m
- 02AGN780A Extension signal cable 5m
- 02AGN780B Extension signal cable 10m
- 02AGN780C Extension signal cable 15m
- 02AGN780D Extension signal cable 20m

\*Use with an adjustable workstage.

# LSM-512S

## Ultra-Wide Range Measuring

- General-purpose type with a wide measurement range of 1mm to 120mm.
- Provides high accuracy with a linearity of  $\pm 6\mu\text{m}$  over the entire measurement range and  $\pm(4.0+0.5\Delta D)\mu\text{m}$  in the narrow range.
- Excellent repeatability of  $\pm 0.8\mu\text{m}$

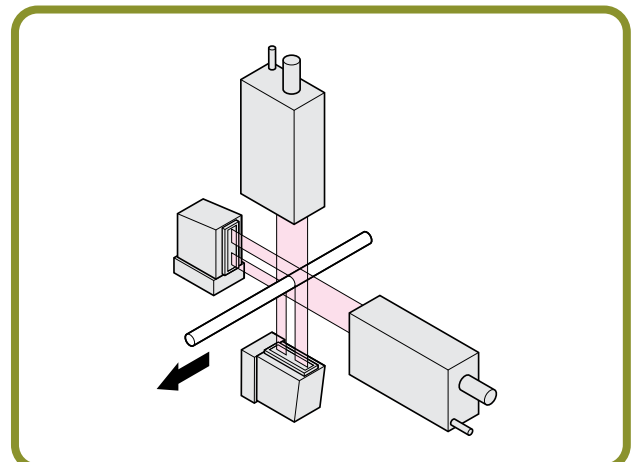

### SPECIFICATIONS

<b>Model</b>	<b>LSM-512S</b>
<b>Order No.</b> (Laser only)	<b>544-540</b>
<b>Package No.</b> (Laser w/LSM 6200 display)	<b>64PKA121</b>
Acceptable standard of laser	IEC, FDA
Measuring range	1 - 120mm (.04" - 4.72")
Resolution (selectable)	0.0001 - 0.1mm (.000005" - .005")
Repeatability* <sup>1</sup>	$\pm 0.85\mu\text{m}$ ( $\pm 32\mu\text{inch}$ )
Linearity	Entire range: $\pm 6.0\mu\text{m}$ ( $\pm 240\mu\text{inch}$ )
at 20°C* <sup>2</sup>	Narrow range: $\pm(4.0+0.5\Delta D)\mu\text{m}$
Positional error* <sup>3</sup>	$\pm 8.0\mu\text{m}$ ( $\pm 320\mu\text{inch}$ )
Measuring region* <sup>4</sup>	30 x 120mm at $\phi 1 - 120\text{mm}$ (1.2" x 4.72" at $\phi .04" - 4.72"$ )
Scanning rate	3200 scans/s
Laser wavelength	650nm, Visible* <sup>5</sup>
Laser scanning speed	904m/s (35590"/s)
Operating temperature	0°C - 40°C
Operating humidity	35 - 85% RH (with no condensation)
Water/Dust protection grade	Conforming to IP64* <sup>6</sup>
Mass	Emission unit: 3.0kg (6.6lbs.), Reception unit: 1.2kg (2.64lbs.), Base: 1.8kg (3.96lbs.), Signal cable: 0.5kg (1.1lbs.)

\*1: Determined by the value for  $\pm 2\sigma$  at the measurement of  $\phi 120\text{mm}$  workpiece with 0.32sec. interval (1024-time average).

\*2: At the center of the measuring region.

\*3: An error due to workpiece shift either in the optical axis direction or in the scanning direction.

\*4: The area given by "measuring range on the optical axis" x "measuring range in the scanning direction."

\*5: FDA Class II/IEC Class 2 semiconductor laser for scanning (Maximum power: 1.3mW)

\*6: The protection level provided for the interior. If the workpiece or glass of the measuring unit window is soiled by water or dust, the unit may malfunction.

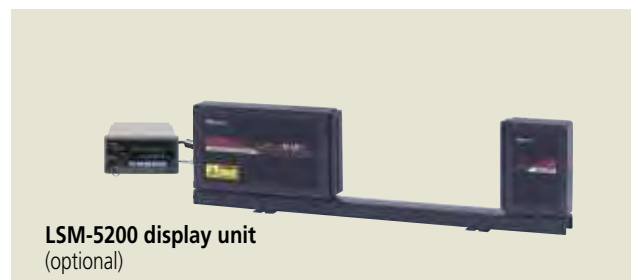
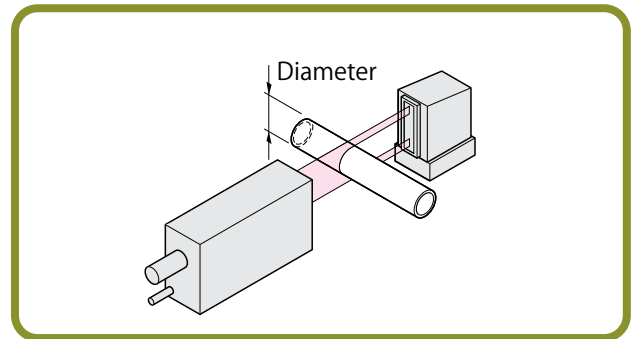

**Dimensions**

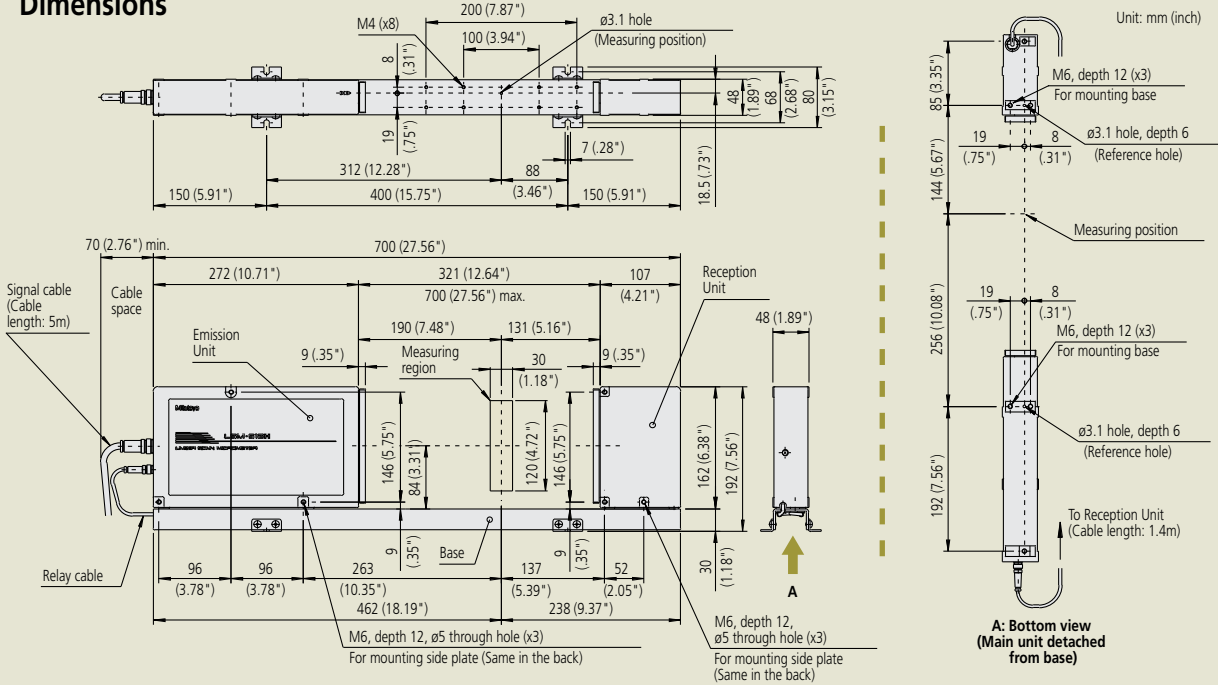

**OPTIONAL ACCESSORIES**



- 957608 Air cleaner for air-screen covers
- 02AGC150A Extension relay cable 1m
- 02AGC150B Extension relay cable 3m
- 02AGC150C Extension relay cable 5m
- 02AGN780A Extension signal cable 5m
- 02AGN780B Extension signal cable 10m
- 02AGN780C Extension signal cable 15m
- 02AGN780D Extension signal cable 20m

# LSM-516S

## Ultra-Wide Range Measuring

- General-purpose type with a wide measurement range of 1mm to 160mm.
- Provides high accuracy with a linearity of  $\pm 7\mu\text{m}$  over the entire measurement range and  $\pm(4.0+2.0\Delta D)\mu\text{m}$  in the narrow range.
- Excellent repeatability of  $\pm 1.4\mu\text{m}$

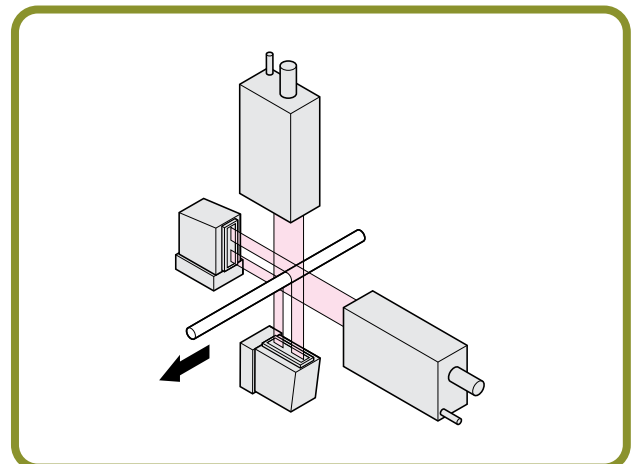

### SPECIFICATIONS

<b>Model</b>	<b>LSM-516S</b>	
<b>Order No.</b> (Laser only)	<b>544-542</b>	
<b>Package No.</b> (Laser w/LSM 6200 display)	<b>64PKA122</b>	
Acceptable standard of laser	IEC, FDA	
Measuring range	1 - 160mm (.04" - 6.30")	
Resolution (selectable)	0.0001 - 0.1mm (.000005" - .005")	
Repeatability* <sup>1</sup>	$\pm 1.4\mu\text{m}$ ( $\pm 55\mu\text{inch}$ )	
Linearity at 20°C* <sup>2</sup>	Entire range	$\pm 7.0\mu\text{m}$ ( $\pm 276\mu\text{inch}$ )
	Narrow range	$\pm(4.0+2.0\Delta D)\mu\text{m}$
Positional error* <sup>3</sup>	$\pm 8.0\mu\text{m}$ ( $\pm 320\mu\text{inch}$ )	
Measuring region* <sup>4</sup>	40 x 160mm at $\phi 1 - 160\text{mm}$ (1.57" x 6.30" at $\phi .04" - 6.30"$ )	
Scanning rate	3200 scans/s	
Laser wavelength	650nm, Visible* <sup>5</sup>	
Laser scanning speed	1206m/s (47480"/s)	
Operating temperature	0°C - 40°C	
Operating humidity	35 - 85% RH (with no condensation)	
Water/Dust protection grade	Conforming to IP64* <sup>6</sup>	
Mass	Emission unit: 7.6kg (16.72 lbs) Reception unit: 3.7kg (8.14 lbs) Base: 2.8kg (6.16 lbs), Signal cable: 0.5kg (1.1 lbs)	

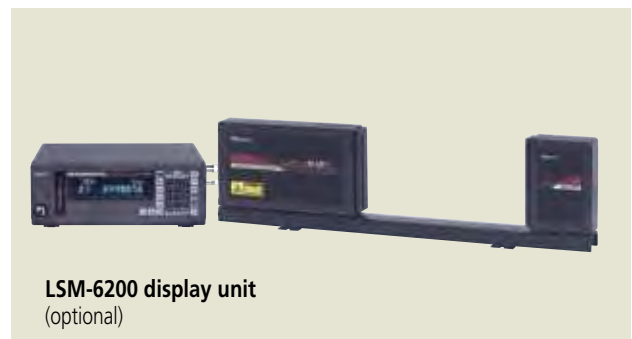
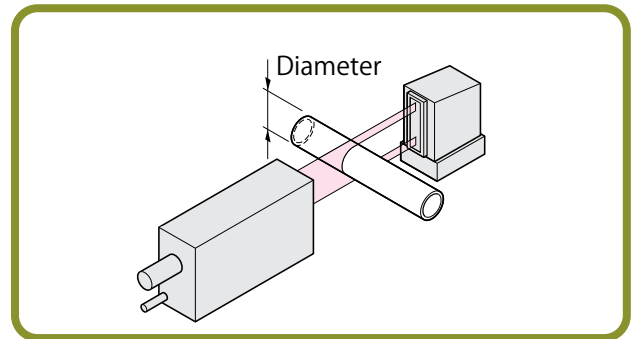

\*1: Determined by the value for  $\pm 2\sigma$  at the measurement of  $\phi 160\text{mm}$  workpiece with 0.32sec. interval (1024-time average).

\*2: At the center of the measuring region.

\*3: An error due to workpiece shift either in the optical axis direction or in the scanning direction.

\*4: The area given by "measuring range on the optical axis" x "measuring range in the scanning direction."

\*5: FDA Class II/IEC Class 2 semiconductor laser for scanning (Maximum power: 1.3mW)

\*6: The protection level provided for the interior. If the workpiece or glass of the measuring unit window is soiled by water or dust, the unit may malfunction.

**Dimensions**

Unit: mm (inch)

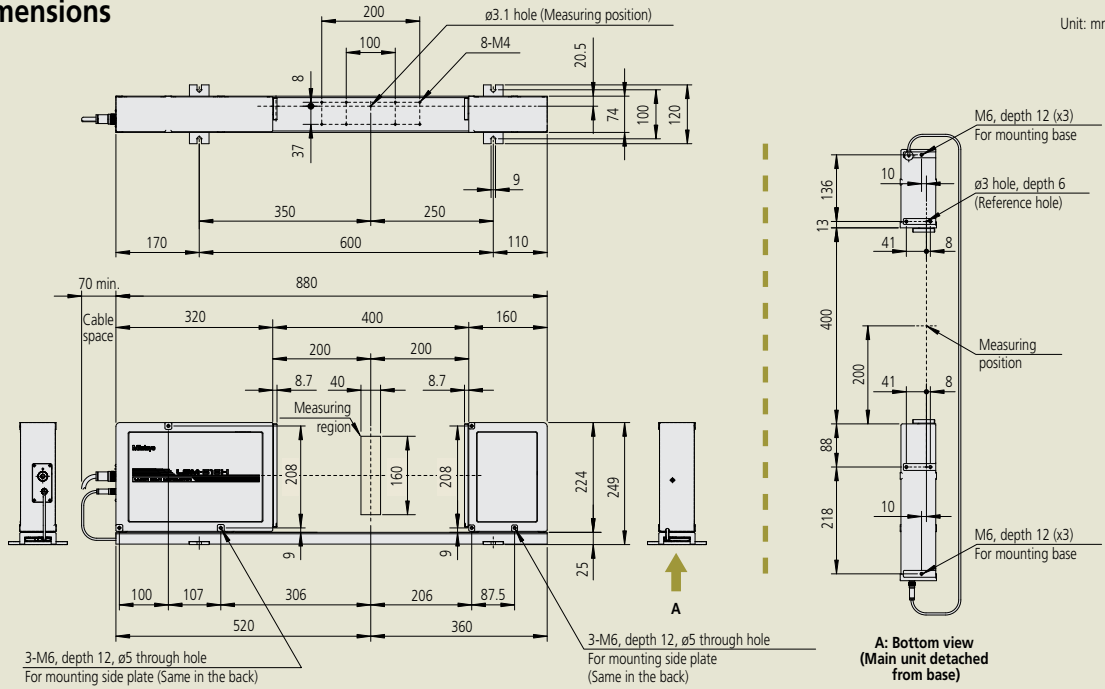

**OPTIONAL ACCESSORIES**

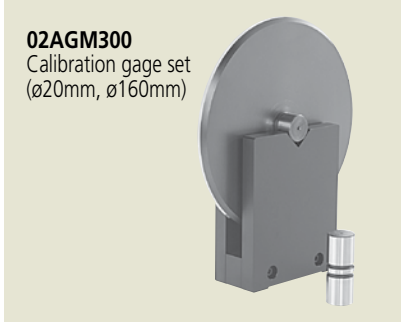

**02AGM300**  
Calibration gage set  
(ø20mm, ø160mm)

- 02AGC150A Extension relay cable 1m
- 02AGC150B Extension relay cable 3m
- 02AGC150C Extension relay cable 5m
- 02AGN780A Extension signal cable 5m
- 02AGN780B Extension signal cable 10m
- 02AGN780C Extension signal cable 15m
- 02AGN780D Extension signal cable 20m

# LSM-9506

## Benchtop with Display Unit

- With a design that integrates the display section and measuring section into one unit, this instrument is best suited for making benchtop measurements in an inspection room.
- A statistical calculation function is provided.
- Standard RS-232C and SPC output interfaces are provided as standard.



### Dimensions

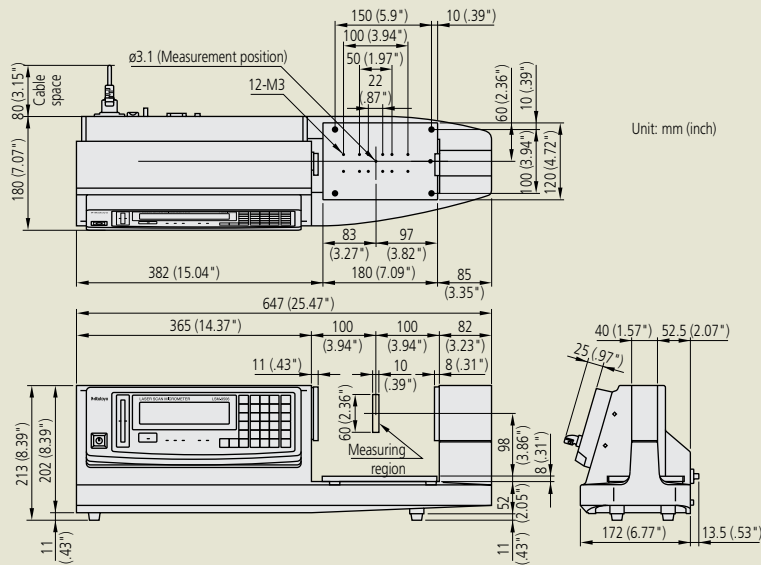

### SPECIFICATIONS

Model	LSM-9506
Order No. (Order no. suffix denotes the AC power cord type equipped.)	120V AC <b>544-116-1A</b>
Type	inch/mm
Measuring range	.02" - 2.36"/0.5 - 60mm
Resolution (selectable)	.000002" - .005"/0.00005 - 0.1mm
Repeatability*1	±0.6µm (±24µinch)
Linearity at 20°C*2	±2.5µm (±100µinch)
Positional error*3	In the optical axis direction: ±2.5µm (±100µinch) In the scanning direction: ±(2.0+L/10µm) (±(.00008+L/10000)")
Measuring region*4	10 x 60mm (.4" x 2.36")
Scanning rate	1600 scans/s
Laser wavelength	650nm, Visible*5
Laser scanning speed	226m/s (8900"/s)
Power supply	120V AC ±10%, 60Hz, 40VA
Data output	Via RS-232C interface, SPC (Digimatic) output port
Functions	(See page 30.)
Operating temperature	0°C - 45°C
Operating humidity	35 - 85% RH (with no condensation)
Mass	13kg (28.6lbs.)

### OPTIONAL ACCESSORIES

For sending data to Quicktool, SPC Software, Excel, or a PLC, see page 34.

**02AGD170**  
Calibration gage set (ø1.0mm, ø60mm)



- 02AGD680** Adjustable workstage
- 02AGD580** Center support\*
- 02AGD590** Adjustable V-block\*
- 936937** SPC output cable (1m)
- 937179T** Footswitch

\*Use with an adjustable workstage.

\*1: Determined by the value for  $\pm 2\sigma$  at the measurement interval of 0.32 sec.

\*2: At the center of the measuring region.

\*3: An error due to workpiece shift either in the optical axis direction or in the scanning direction. L= Distance between the center of workpiece and the center of optical axis (in mm or inches).

\*4: The area given by "measuring range on the optical axis" x "measuring range in the scanning direction."

\*5: FDA Class II (**544-116-1A**) semiconductor laser for scanning (Maximum power: 1.0mW)

# Optional Accessories

## Calibration Gage Sets

- The calibration gage sets are made up of precision disks, cylinders or wires used for calibrating Laser Scan Micrometers. Each gage that may be measured in alternate positions is marked at the position where the calibration measurement was made.



Order No.	Application	Components
<b>02AGD110</b>	LSM-500S	ø0.1mm gage (958200) ø2mm gage (958202) Gage stand (02AGD111) Set case (958203)
<b>02AGD120</b>	LSM-501S	ø0.1mm gage (958200) ø10mm gage (229317) Gage stand (02AGD121) Set case (958203)
<b>02AGD180</b>	LSM-6902H	ø1mm gage (02AGD920) ø25mm gage (02AGD963)
<b>02AGD130</b>	LSM-503S	ø1mm gage (02AGD920) ø30mm gage (02AGD961) Gage stand (02AGD131) Set case (02AGD980)
<b>02AGD140</b>	LSM-506S	ø1mm gage (02AGD920) ø60mm gage (02AGD962) Gage stand (02AGD141) Set case (02AGD980)
<b>02AGD150</b>	LSM-512S	ø20mm gage (229730) ø120mm gage (234072) Gage stand (02AGD151) Set case (02AGD990)
<b>02AGM300</b>	LSM-516S	ø20mm gage (229730) ø160mm gage (02AGM303) Gage stand (02AGM320) Set case (02AGM310)
<b>02AGD170</b>	LSM-9506	ø1mm gage (02AGD920) ø60mm gage (02AGD962) Gage stand (02AGD171) Set case (02AGD970)

## Extension Signal Cables

- Used to extend the supplied signal cable if the measuring unit and display unit need to be placed further apart from one another.

## Extension Relay Cables\*

- Used to extend the supplied relay cable if the emission unit and reception unit need to be placed further apart from one another.

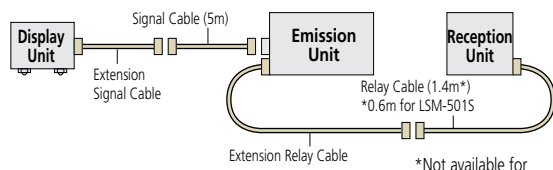

## Extension signal cables

Order No.	Cable length
<b>02AGN780A</b>	5m
<b>02AGN780B</b>	10m
<b>02AGN780C</b>	15m
<b>02AGN780D</b>	20m

## Extension relay cables

Order No.	Cable length
<b>02AGC150A</b>	1m
<b>02AGC150B</b>	3m
<b>02AGC150C</b>	5m

Note 1: The maximum length of the LSM-500S/501S signal cable is 20m, and that of the relay cable is 2m. The maximum length of the signal and relay cables of models other than those mentioned above should be 30m or less and 5m or less, respectively.  
 Note 2: The total length of signal and relay cables should not be more than 32m.

## Workstage

- Aids shaft measurement by providing a V-block mounting and an up/down adjustment mechanism.

Order No.	Application
<b>02AGD270</b>	LSM-501S LSM-503S LSM-6902H



## Wire Guiding Pulleys

- This jig is for guiding thin filaments, such as fine magnet wire or optical fiber, so that a stable measurement of the outside diameter can be made.



Order No.	Application	Maximum measuring dia.
<b>02AGD200</b>	LSM-500S	1.6mm (.063")
<b>02AGD210</b>	LSM-501S	2mm (.079")

Note: Use the calibration gage set (02AGD110) for both types of wire guiding pulley.

## Air-Screen System

- If using your LSM in a smoky or dusty environment, an air-screen system consisting of two covers per unit and a central air cleaner/regulator can be used to help prevent the emission/reception windows from being soiled.

Air cleaner/regulator: **957608**

Air-screen covers

Order No.	Application	No. of pcs.*
<b>02AGD220</b>	LSM-500S	6 pcs.*
<b>02AGD230</b>	LSM-501S	6 pcs.*
<b>02AGD240</b>	LSM-503S	3 pcs.*
<b>02AGD250</b>	LSM-506S	1 pc.*
<b>02AGD260</b>	LSM-512S	1 pc.*

\* No. of pcs. concurrently usable with one air cleaner/regulator.



## Accessories

# Adjustable Workstages

- Aids in measuring workpiece diameter by means of up/down and right/left slide adjustments.
- Optimum for quality control of precision shafts, rollers, pin gages, etc.

### For LSM-6902H/6900

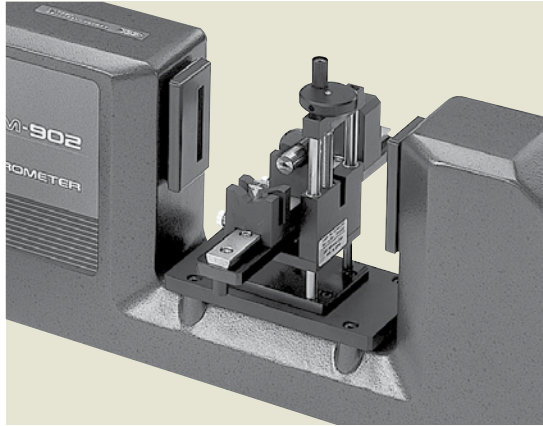

Unit: mm (inch)

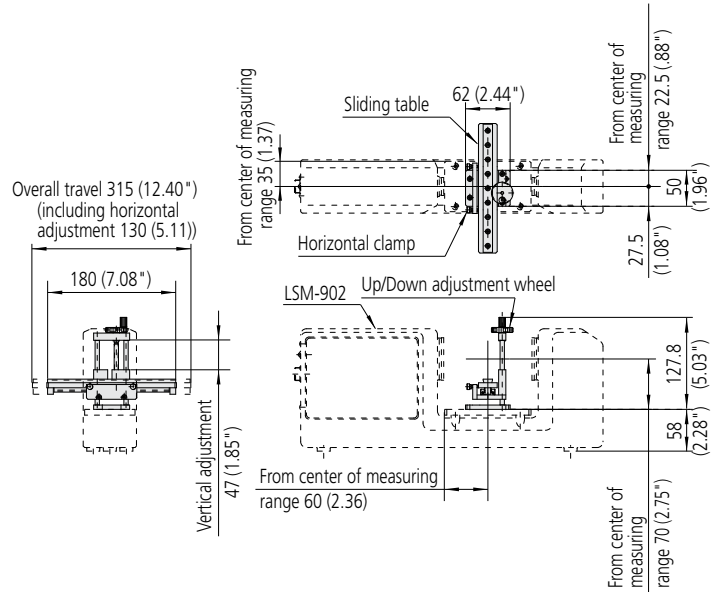

### SPECIFICATIONS

Order No.	02AGD280
Application	LSM-6902H
Horizontal adjustment	130mm (5.12")
Vertical adjustment	47mm (1.85")
Maximum table loading	0.5kg (1.1lbs.)
Mass	0.8kg (1.8lbs.)
Standard accessories	<ul style="list-style-type: none"> <li>● V-block (02AGD420) x 2pcs.</li> <li>● Workpiece stop (02AGD430)</li> </ul>

### For LSM-501S

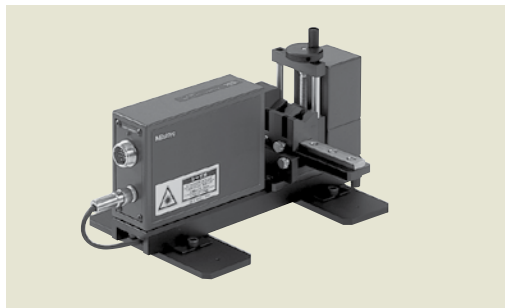

Unit: mm (inch)

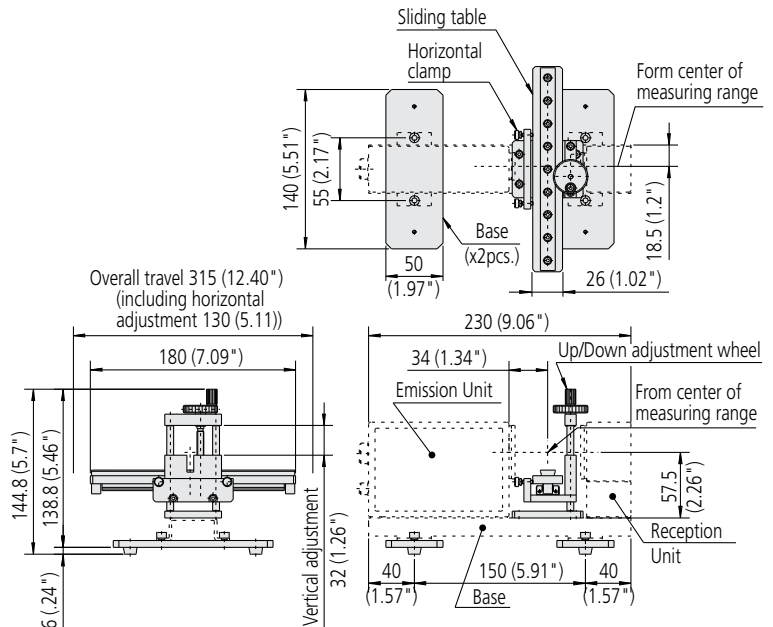

### SPECIFICATIONS

Order No.	02AGD400
Application	LSM-501S
Horizontal adjustment	130mm (5.12")
Vertical adjustment	32mm (1.26")
Maximum table loading	0.5kg (1.1lbs.)
Mass	1.0kg (2.2lbs.)
Standard accessories	<ul style="list-style-type: none"> <li>● V-block (02AGD420) x 2pcs.</li> <li>● Workpiece stop (02AGD430)</li> </ul>



For LSM-503S



Unit: mm (inch)

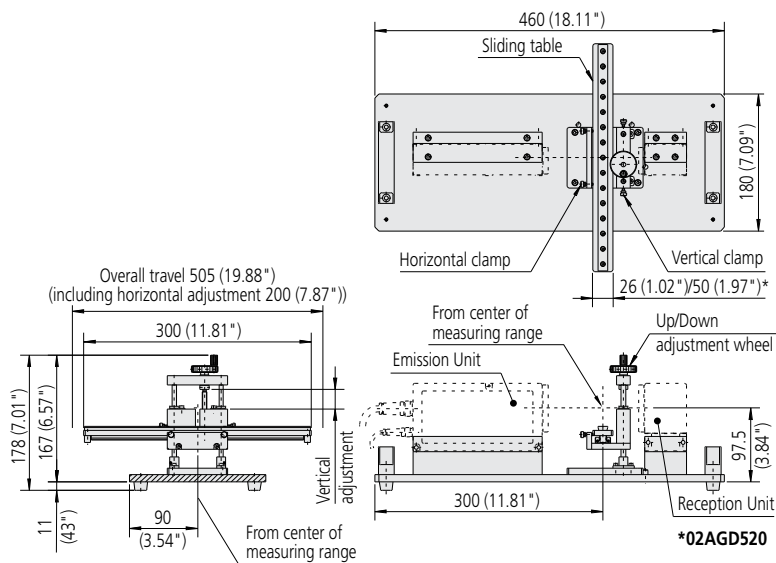

SPECIFICATIONS

Order No.	02AGD490
Application	LSM-503S
Horizontal adjustment	200mm (7.87")
Vertical adjustment	35mm (1.38")
Maximum table loading	2.0kg (4.4lbs.)
Mass	4.9kg (10.78lbs.)
Standard accessories	<ul style="list-style-type: none"> <li>•V-block (02AGD420) x 2pcs.</li> <li>•Workpiece stop (02AGD430)</li> </ul>

Standard Accessories

V-blocks

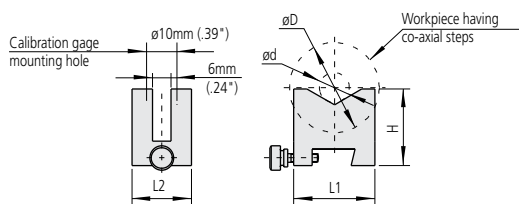

Unit: mm (inch)

Order No.	02AGD420
øD max.	30 (1.18")*
ød max.	30 (1.18")*
D - d max.	25 (.98")**
H	25.5 (1")
L1	27 (1.06")
L2	20 (.79")
Mass	0.03kg
Calibration gages to be used	•ø0.1mm •ø1mm •ø10mm •ø30mm

\*10 (.39") for LSM-501S

\*\*25 (.98") for LSM-6902H

Workpiece stop

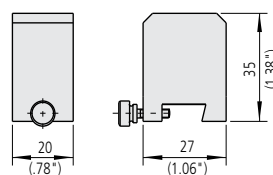

Order No.	02AGD430
Mass	0.05kg

## Accessories

# Adjustable Workstages

- Aids in measuring workpiece diameter by means of up/down and right/left slide adjustments.
- Optimum for quality control of precision shafts, rollers, pin gages, etc.

### For LSM-506S

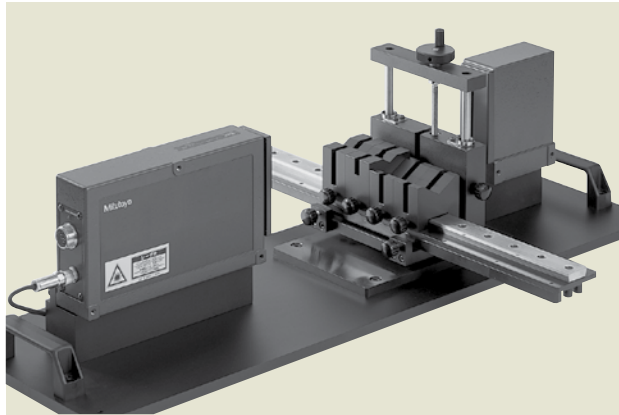

#### SPECIFICATIONS

<b>Order No.</b>	<b>02AGD520</b>
Application	LSM-506S
Horizontal adjustment	300mm (11.81")
Vertical adjustment	45mm (1.77")
Maximum table loading	5.0kg (11lbs.)
Mass	9.7kg (21.34lbs.)
Standard accessories	<ul style="list-style-type: none"> <li>● V-block (02AGD550) x 2pcs.</li> <li>● V-block (02AGD560)</li> <li>● V-block (02AGD570)</li> </ul>

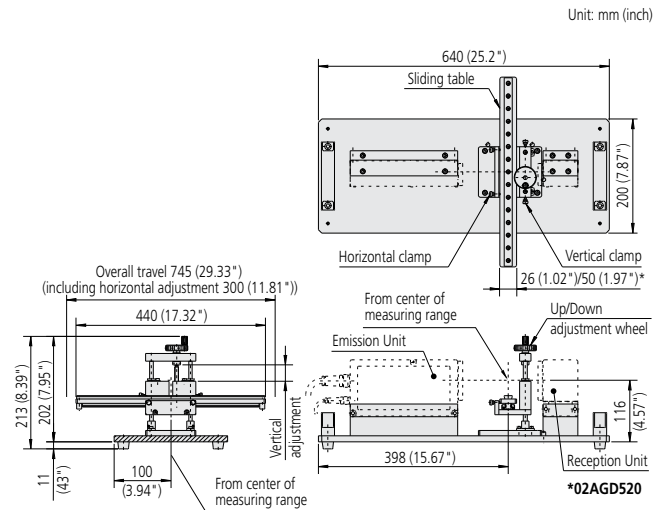

### For LSM-9506

#### SPECIFICATIONS

Order No.	02AGD370	02AGD680
Application	LSM-9506	
Horizontal adjustment	200mm (7.87")	300mm (11.81")
Vertical adjustment	45mm (1.77")	
Maximum table loading	2.0kg (4.4lbs.)	5.0kg (11lbs.)
Mass	3.8kg (8.4lbs.)	4.8kg (10.56lbs.)
Standard accessories	<ul style="list-style-type: none"> <li>● V-block (02AGD550) x 2pcs.</li> <li>● V-block (02AGD560)</li> <li>● V-block (02AGD570)</li> </ul>	

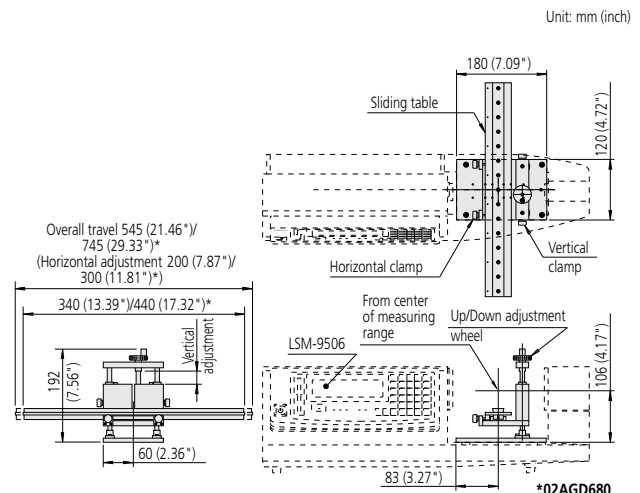

## Standard Accessories for Workstages\*

### V-blocks

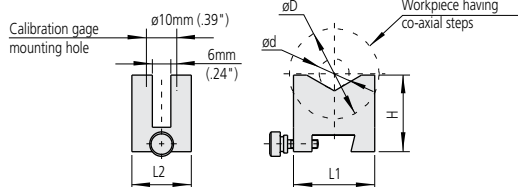

Unit: mm (inch)

Order No.	02AGD550	02AGD560	02AGD570
$\phi D$ max.	60 (2.36")	60 (2.36")	60 (2.36")
$\phi d$ max.	60 (2.36")	30 (1.18")	30 (1.18")
D - d max.	30 (1.18")	50 (1.97")	50 (1.97")
H	39 (1.54")	45 (1.77")	45 (1.77")
L1	50 (1.97")	50 (1.97")	50 (1.97")
L2	30 (1.18")	30 (1.18")	30 (1.18")
Mass	0.12kg	0.15kg	0.15kg
Calibration gages to be used	<ul style="list-style-type: none"> <li><math>\phi 10</math>mm</li> <li><math>\phi 30</math>mm</li> </ul>	<ul style="list-style-type: none"> <li><math>\phi 10</math>mm</li> <li><math>\phi 30</math>mm</li> <li><math>\phi 60</math>mm</li> </ul>	<ul style="list-style-type: none"> <li><math>\phi 1</math>mm</li> <li><math>\phi 10</math>mm</li> <li><math>\phi 30</math>mm</li> </ul>

## Optional Accessories for Workstages\*

### Adjustable V-blocks

- Optional accessories for adjustable workstages.

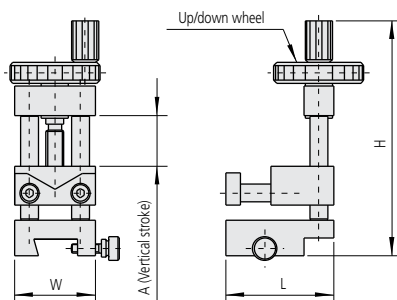

Unit: mm (inch)

Order No.	02AGD450	02AGD590
H	78.8 (3.1")	105.8 (4.17")
L	36 (1.42")	40 (1.57")
W	27 (1.06")	50 (1.97")

### Center Supports

- Optional accessories for adjustable workstages.

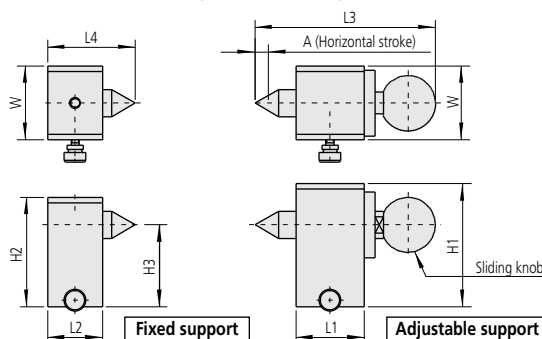

Unit: mm (inch)

Order No.	02AGD440	02AGD580
H1	45 (1.77")	65 (2.56")
H2	40 (1.57")	60 (2.36")
H3	30 (1.18")	45 (1.77")
L1	25 (.98")	50 (1.97")

Unit: mm (inch)

Order No.	02AGD440	02AGD580
L2	20 (.79")	40 (1.57")
L3	66 (2.60")	106.5 (4.19")
L4	32 (1.26")	55 (2.17")
W	27 (1.06")	50 (1.97")

## SPECIFICATIONS

Order No.	02AGD450	02AGD590
Application	Adjustable workstage for LSM-501S ( <b>02AGD400</b> ), Adjustable workstage for LSM-6902H ( <b>02AGD280</b> ), Adjustable workstage for LSM-503S ( <b>02AGD490</b> )	Adjustable workstage for LSM-506S ( <b>02AGD520</b> ), Adjustable workstage for LSM-9506 ( <b>02AGD680</b> )
Vertical adjustment (A)	20mm (.79")	35mm (1.38")
Maximum workpiece diameter	30mm (1.18")	60mm (2.36")
Mass	0.1kg	0.2kg

\*02AGD520, 02AGD370, 02AGD680

## SPECIFICATIONS

Order No.	02AGD440	02AGD580
Application	Adjustable workstage for LSM-501S ( <b>02AGD400</b> ), Adjustable workstage for LSM-6902H ( <b>02AGD280</b> ), Adjustable workstage for LSM-503S ( <b>02AGD490</b> )	Adjustable workstage for LSM-506S ( <b>02AGD520</b> ), Adjustable workstage for LSM-9506 ( <b>02AGD680</b> )
Point angle	60°	60°
Maximum workpiece length	110mm (4.33") on <b>02AGD400/02AGD280</b> 230mm (9.06") on <b>02AGD490</b>	315mm (12.4") on <b>02AGD520</b> on <b>02AGD680</b>
Horizontal adjustment (A)	5mm (.2") or more	10mm (.39") or more
Center point clamping force	1.1kgf	3.2kgf
Mass	0.18kg (.4lbs.)	0.85kg (1.87lbs.)

# LSM-5200

## Compact (Panel-mount) Display Unit

- Panel-mount (with dimensions conforming to DIN standards) allows easy system integration.
- Capable of calculating mean, maximum, minimum and range (maximum - minimum).
- Segment measurement (7 segments max.) or edge measurement (1 to 255 edges) can be selected.
- USB2.0, RS-232C and I/O-Analog interfaces are provided as standard.
- Arithmetical average or moving average can be selected.
- Go/no-go judgment function.

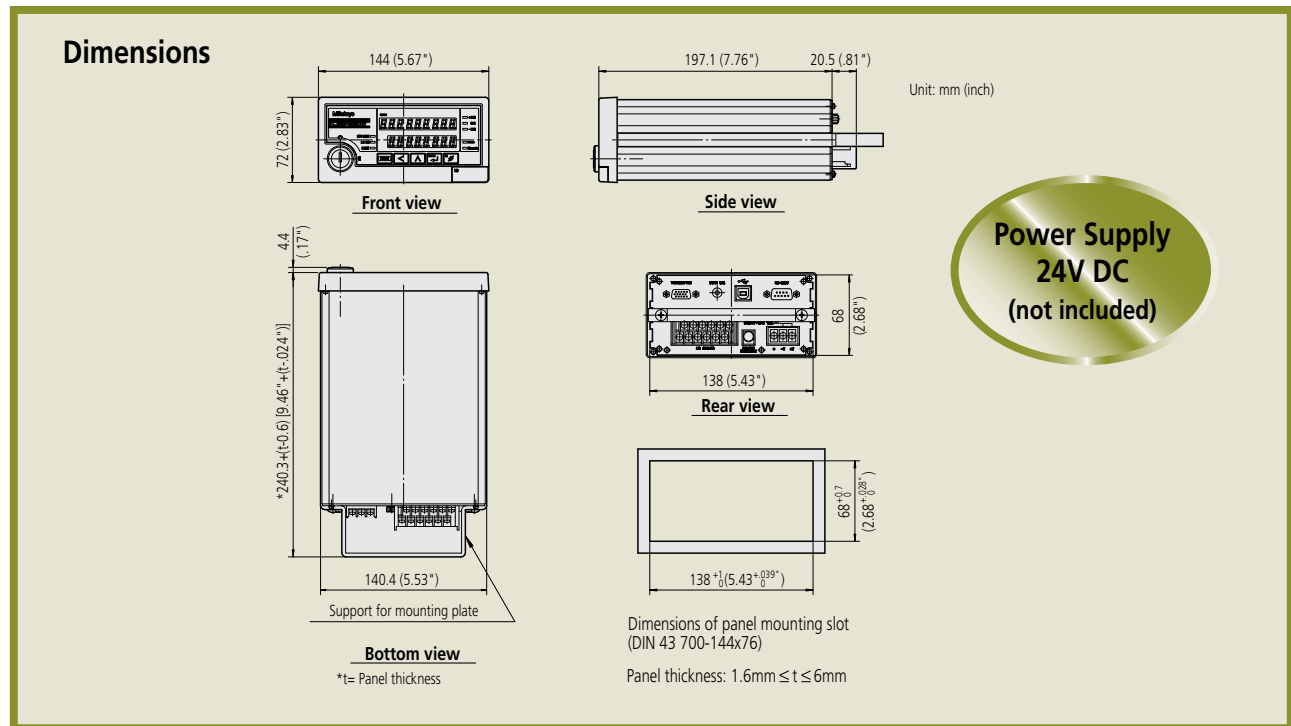

### SPECIFICATIONS

Model	LSM-5200
Order No.	544-047
Display	9-digit LED (for measurement) & 8-digit LED (sub-display)
Segment designation	Seg.1 to Seg.7 (Seg.1 - Seg.3 for transparent objects)
Edge designation	1 to 255 edges can be detected*1
Averaging times*2	Arithmetical average: per 1 to 2048, moving average: per 32 to 2048
Go/no-go judgment	Nominal value ±tolerance setting, upper & lower limits setting
Measurement mode	Waiting, single measurement, continuous measurement
Statistical calculation	Available when connecting an external PC via the RS-232C or USB interfaces
Power supply	+24V DC ±10%, 1.3A (not included)
Data output	USB2.0, RS-232C and I/O-Analog interfaces
Functions	(See page 30.)
Operating temperature	0°C - 45°C
Operating humidity	35 - 85% RH (with no condensation)
Mass	1.4kg (3.08 lbs.)

\*1: With the **LSM-500S** the measuring range will be set to between 0.1 and 2mm if edge measurement is selected for 1 to 255 edges or if the automatic workpiece detecting function is on.

\*2: With the **LSM-500S** the number of scans will be limited to between 16 and 2048 for both arithmetical and moving averages if the ultra-fine wire measurement function is on.

# LSM-6200

## Multi-function Display Unit

- With a dual-display design setup values can be continuously monitored. Also, two measurement value items can be displayed on the sub-display with the simultaneous measurement function.
- Either segment measurement (7 segments max.) or edge measurement (1 to 255 edges) can be selected.
- RS-232C and I/O-Analog interfaces are provided as standard.
- A statistical calculation function and abnormal data eliminating function are provided.

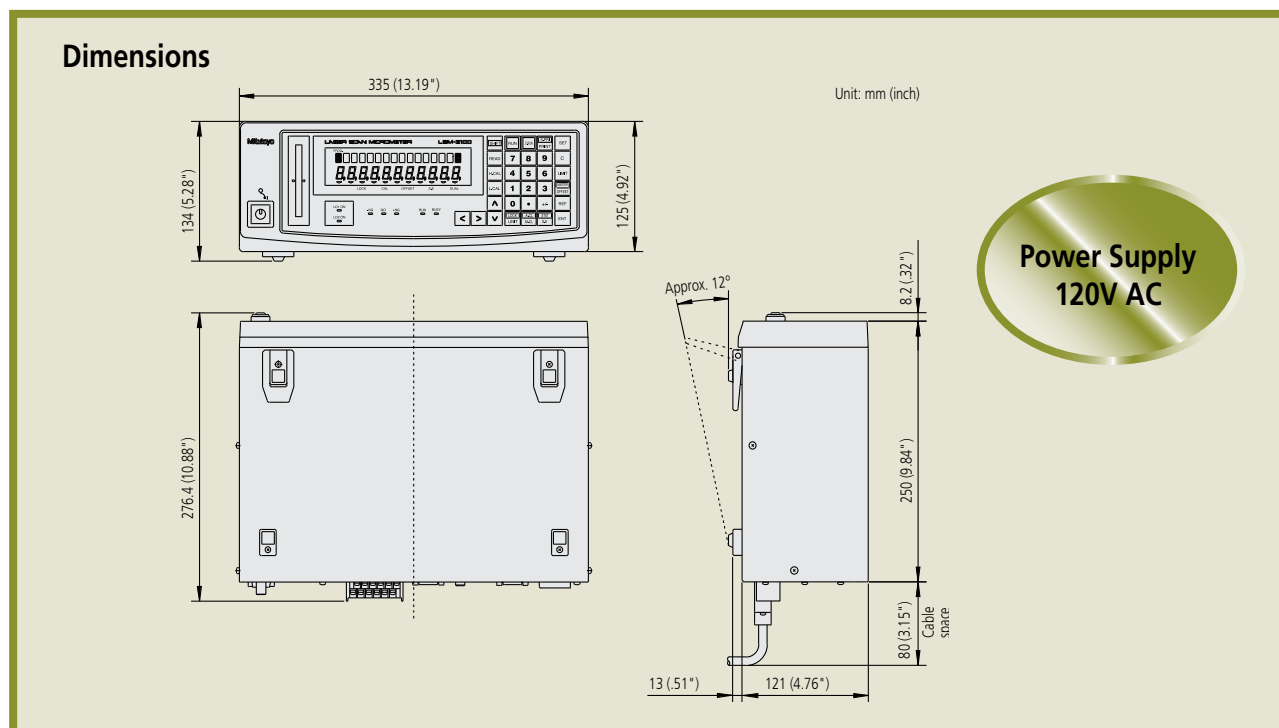

### SPECIFICATIONS

Model	LSM-6200
Order No. (Order no. suffix denotes the AC power cord equipped.)	544-072A
Type	inch/mm
Display	16-digit fluorescent tube (for measurement) & 11-digit fluorescent tube (sub-display)
Segment designation	Seg.1 to Seg.7 (Seg.1 - Seg.3 for transparent objects)
Edge designation	1 to 255 edges can be detected*1
Averaging times*2	Arithmetical average: per 1 to 2048, moving average: per 32 to 2048
Go/no-go judgment	Nominal value $\pm$ tolerance setting, upper & lower limits setting, multi-limit setting
Measurement mode	Waiting, single measurement, continuous measurement
Statistical calculation	Maximum measurement (MAX), minimum measurement (MIN), mean, range (MAX-MIN), standard deviation ( $\sigma$ )
Power supply	120V AC $\pm$ 10%, 60Hz, 40VA
Data output (as standard)	Via RS-232C and I/O-Analog interfaces
Functions	(See page 30.)
Operating temperature	0°C - 45°C
Operating humidity	35 - 85% RH (with no condensation)
Mass	5kg (11lbs.)

\*1: With the LSM-500S the measuring range will be set to between 0.1 to 2mm if the edge measurement is selected for 1 to 255 edges or if the automatic workpiece detecting function is on.  
 \*2: With the LSM-500S the number of scans will be limited to between 16 and 2048 for both the arithmetical and moving averages if the ultra-fine wire measurement function is on.

# LSM-5200/6200/6900/9506 Functions

## Measuring Setup Memory

The measuring setup can be registered as a program and saved (LSM-6200: 100 programs, LSM-6900: 10 programs, LSM-5200: 1 program). These programs can be recalled with a single operation.

## Multiple Calibration Data Memory Function

This function allows storage of 10 types of calibration data. In this function mode, up to 10 sets of 10 programs are available in hand.

- 10 programs (a piece of calibration data) X 10 sets
- \* Only LSM-6200 has this function.

## Drill/Endmill (odd number flute) diameter measurement

The diameter of drills or endmills that have an odd number of flutes can be measured by changing the parameter set up.

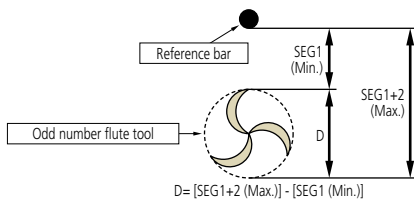

## Automatic Workpiece Detection

This function automatically starts measurement when a workpiece advances into the specified measuring area.

## Preset/Offset

Sets the currently displayed measurement value to zero or a specified numeric value. This is useful, for example, if a difference in the diameters of a reference gage and a workpiece is to be allowed for in calibration, or if a dimension of a workpiece that exceeds the measurement range of the LSM is to be measured.

## Mastering

For continuous processing of high-precision workpieces, fine-adjusting the preset or offset value is called mastering. By specifying a mastering value, the total correction will be (zero-set/offset value) + (±mastering value). If a positive mastering value is specified, the displayed value for a workpiece diameter measurement will be greater than the actual value. If a negative value is specified, the displayed value will be smaller than the actual value.

## Sample Measurement

On a sample measurement the number of measurements will be defined (in the range of 2 to 999) in advance. From this sample, measurement various calculation results (mean, maximum, minimum, and range) can be derived. These measurements can be used for runout measurements on a revolving workpiece and simplified cylindricity measurements.

## Arithmetical Average/Moving Average

Arithmetical/moving average modes are provided to obtain the average of measurement values. On this type of LSM, either of them can be specified before starting measurement. In the arithmetical average mode, the number of scans over which to take an averaging can be set at one of twelve steps between 1 (0.32ms) and 2048 (0.64sec). In the moving average mode, the number of scans can be set at one of seven steps between 32 (0.01sec) and 2048 (0.64sec), and the measurement value will be updated every sixteen scans on and after the second measurement, irrespective of the specified number of scans for averaging. The latter mode is suitable for judging the trend in the diameter or width of an endless workpiece, such as wire or tape from a measurement that requires a long period.

## Measurement using Segment Specification

The following conventions are used to set up to the maximum of seven segments. However, if the transparent object measuring mode is set, no more than three segments can be set at one time.

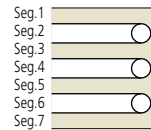

- Measurement of spacing of two parallel pins (pitch measurement)  
Pitch = ((Seg.2+Seg.4)/2)+Seg.3

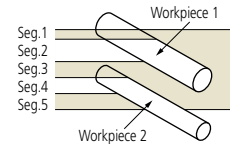

- The Runout of a revolving workpiece can be obtained by observing the variation in Seg.1 which is measured against a stationary reference pin.

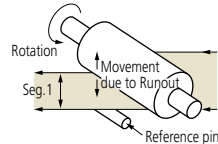

- The outside diameter of a wire or cylindrical workpiece can be measured by using Seg.2.

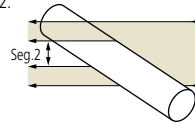

- The outside diameter of a large workpiece can be measured by using Seg.1 and Seg.5 in a dual-unit configuration. (only with LSM-6200).

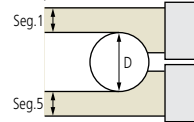

- If dimensions in both X and Y directions (min. distance of X/Y scanning section: 10mm) are measured through dual-unit measurement, use Seg.2 and Seg.6 (only with LSM-6200).

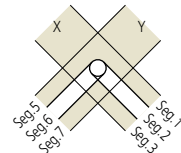

## Automatic Measurement using Edges

The edges created by scanning a workpiece can be used to program an LSM. A maximum of 127 workpiece features, and 127 of the spaces between these features, can be used, which involves a total of 255 edges. This is most useful for measuring such things as IC chip leads or connector pins that are approximately equally spaced. This method cannot be applied to transparent objects.

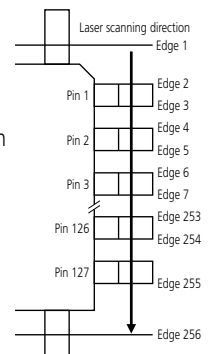

### External trigger signal input\* \*Not available for LSM-5200

By supplying a contact signal to the footswitch connector at the rear panel of the LSM-6200/6900/9506, the measurement can be triggered.

### Abnormal Data Elimination

If a piece of data significantly exceeds the tolerance limit because the workpiece or measuring unit is contaminated by a water droplet, oil droplet or dust, the piece of data will be automatically removed by this function.

### Data Output Interval Setting

By setting an interval (between 1 and 999 seconds) to continuous measurement in advance, data output will take place at each specified period of time.

### Statistical Calculation

With this function, multiple measurements are taken from the same type of workpiece, statistical values are calculated from the measurement results and quality evaluation is executed for each lot.

- Example of measuring a stepped cylinder using the statistical calculation function.

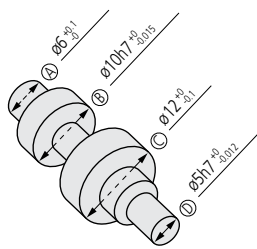

Measuring procedure: Measure the dimensions numbered (A) to (D), perform tolerance judgment, and statistically process the resulting data for every ten samples defined as one lot.

P:0 +NG	6.1700
P:0 -NG	5.7240
STAT. DATA	
PROGRAM NO. = 0	(A)
N	10
S	6.0045
MAX	6.0155
MIN	5.9970
R	0.0185
S.D	0.00600
STAT. DATA	
PROGRAM NO. = 1	(B)
N	10
S	9.9990
MAX	9.9950
MIN	9.9775
R	0.0175
S.D	0.00530
STAT. DATA	
PROGRAM NO. = 2	(C)
N	10
S	11.9485
MAX	11.9635
MIN	11.9145
R	0.0490
S.D	0.01900
STAT. DATA	
PROGRAM NO. = 3	(D)
N	10
S	4.9930
MAX	5.0160
MIN	4.9505
R	0.0655
S.D	0.01485

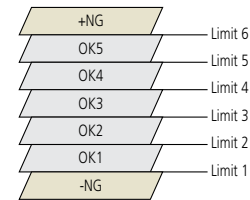

### Data Output

Every model has a standard RS-232C interface unit, allowing data to be output to an external PC or printer.

The LSM-5200/6200 has the standard I/O-Analog output interface that allows the LSM to be connected to a sequencer, etc. The SPC (Digimatic Code) output interface is standard with the LSM-9506, allowing for easy construction of a quality control system. With the LSM-6200 there are additional means of data output, including SPC, BCD and GP-IB output interfaces.

### Multi-Limit Judgment\* \*Not available for LSM-5200

In addition to +NG, GO, and -NG judgment criteria limit values from Limit 1 to Limit 6 can also be set. If an optional 2nd I/O-Analog interface unit (02AGC880) is used with the LSM-6200/6900/9506, seven-step judgment signals can be output to external devices to support go/no-go judgment.

### Simultaneous (Dual-program) Measurement\* \*Not available for LSM-5200

It is possible to measure two items simultaneously with one Laser Scan Micrometer unit, and to output the data. This function can be used to simultaneously measure the outside diameter and runout of a bar that is rotating, or to measure the outside diameters of two cylinders or wires at the same time.

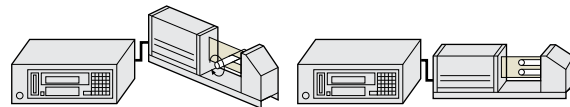

### Restrictions Associated with Particular Combinations of Functions

Combinations of Functions	Edge specification		Transparent object measurement	Ultra-fine wire measurement*	Automatic workpiece detection	Abnormal data elimination	Sample measurement	Moving average	Group judgment**
	Manual measurement	Automatic measurement							
Edge specification	Manual measurement	—	—	—	●	●	●	●	●
Edge specification	Automatic measurement	—	—	—	●	—	—	—	—
Transparent object measurement	—	—	—	●	●	●	●	●	●
Ultra-fine wire measurement*	—	—	●	—	—	●	●	●	●
Automatic workpiece detection	●	●	●	—	—	●	●	—	●
Abnormal data elimination	●	—	●	—	●	—	●	●	●
Sample measurement	●	—	●	●	●	●	—	●	●
Moving average	●	—	●	●	—	●	●	—	—
Group judgment**	●	—	●	●	●	●	●	—	—

●: Permitted combination, —: Combination that is not permitted  
 \*Function that is not provided for LSM-9506  
 \*\*Function that is not provided for LSM-5200

# LSM-5200/6200/6900/9506 Data I/O Specifications

## RS-232C Interface

Allows the LSM to communicate with external devices via RS-232C (conforming to the EIA standard) serial signals. Depending on the basic setup, this interface can be used as a printer port.

### Pin assignment of the connector

Matching plug: D-sub 9-pin (female)

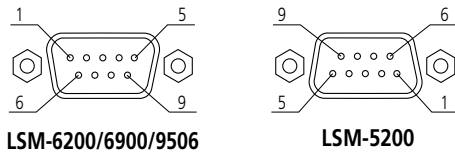

### Communication specifications

Definition of device	DTE definition on the side of LSM	
Data transmission method	All-duplex transmission	
Synchronizing method	Start-stop system	
Data transmission speed	6200	4800, 9600, 19200, 38400bps
	5200, 6900	1200, 2400, 4800, 9600, 19200bps
Data arrangement	Transmission code	ASCII
	Data length	7 or 8 bits
	Start bit	1 bit
	Parity check	Non, odd or even
	Delimiter	CR+LF, CR, LF

### Commands

Various external commands, including those for setting measuring conditions, setting the measurement mode, starting measurement, and requesting statistical calculation, are supported. This allows the user to control the LSM from an external unit (e.g. PC) for customized measurements.

### Connections

(1) Connecting the RS-232C interface to a device specified as a terminal (DTE)

#### Example 1: Flow control method (handshake method controlled by CTS, DSR, DTR, and RTS signals)

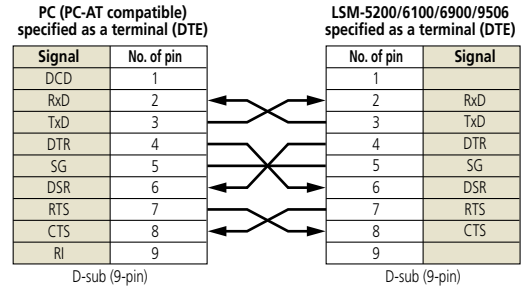

#### Example 2: Flow control method (handshake method controlled by CTS, DSR, DTR, and RTS signals)

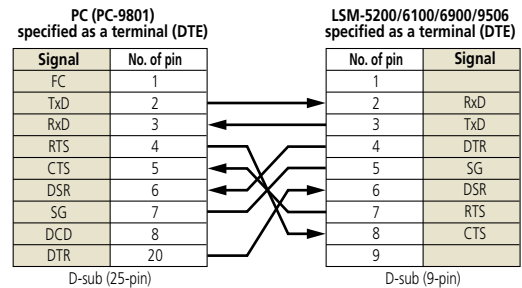

#### Example 3: 3-Wire method (teletype protocol using TxD, RxD and SG)

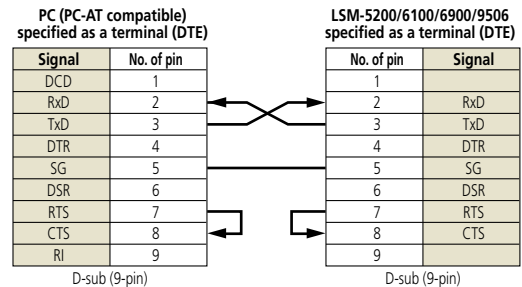

(2) Connecting the RS-232C interface to a device specified as a modem (DCE)

#### Example 1: Flow control method (handshake method controlled by CTS, DSR, DTR, and RTS signals)

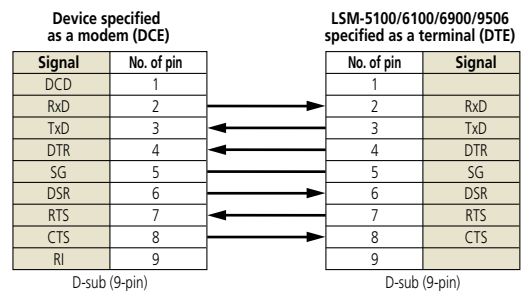



\*Not available for LSM-9506

### I/O-Analog Interface\*

Used to communicate with a PC, programmable controller, or relay circuitry by means of sequential signals. It is also capable of producing an analog voltage output that may be used for feedback control and/or continuous recording of workpiece dimension deviation.

### External view of the connector

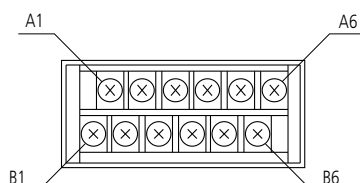

### Pin assignment (of LSM-6200/6900)

Terminal	Signal	Function	I/O
A1	FG	Frame ground (Used for connecting the shield conductor of I/O signal cables)	—
A2	STS	Output of measurement condition (Goes high in the event of "Err-0")	OUT
A3	$\overline{GO}$	Go/no-go judgment result output ( $\overline{GO}$ ) (Can be changed to strobe signal ( $\overline{STB}$ ) or measurement in-progress signal ( $\overline{ACK}$ ) output by the basic setup)	OUT
A4	+NG	Go/no-go judgment result output (+NG)	OUT
A5	-NG	Go/no-go judgment result output (-NG)	OUT
A6	GND	Digital ground (Common ground terminal of both output (A2 thru A5) and input (B4 thru B6))	—
B1	FG	Frame ground (Used for connecting the shield conductor of I/O signal cables)	—
B2	ALG	Analog voltage output	OUT
B3	0V	0V reference for analog voltage output	OUT
B4	OFFS	Offset input (Can be changed to (HOLD) by the basic setup)	IN
B5	RUN	Input of trigger command for single-run measurement (Can be changed to a trigger for continuous-run measurement (with term specification))	IN
B6	RES	Input of CLEAR command	IN

Note: The pin assignment for the LSM-5100 may differ.

### Input/output equivalent circuit

(1) Input circuit

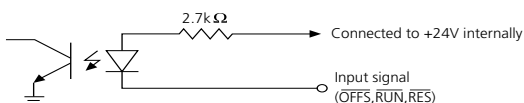

- Low-level signal to be between 0 and 1V. Generally drive this circuit with an open collector-type transistor.
- Maximum current drawn from the input signal terminal is 12mA.

(2) Output circuit

1. Control signal output

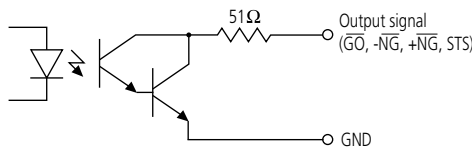

- Maximum rating of the output transistor is 30V, 50mA.

2. Analog signal output

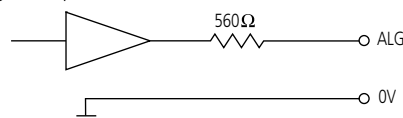

- The output voltage range is  $\pm 5V$ .
- The accuracy of the analog voltage output is 0.2% of full-scale range.
- This analog output should be connected to a device that has an input impedance of  $1M\Omega$  or greater. If the input impedance is lower than this value, the output accuracy will be reduced due to the internal resistance of  $560\Omega$ .

### Remote Interlock Connector

The Remote Interlock Connector is provided as a means of turning the laser beam on and off from a remote location. Since the supplied short-circuit pin is usually inserted in this terminal, the circuit is short-circuited. Insert an optional switched plug to allow external control of the LSM laser.

Laser emission ON: Short-circuit pin inserted  
Laser emission OFF: Short-circuit pin removed



No.214938

### Scanning Signal Connector

The Scanning Signal Connector is provided for observing the output signal waveform from the reception chip in the measuring unit. Typically, this connector is used to align the emission unit and reception unit after they have been removed from the original base and then mounted on a different base.



No.02AGC401

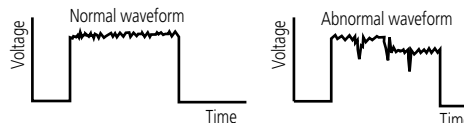

# Optional Accessories

**Optional accessories to connect to QuickTool (data can be saved as XLS file & later opened in Excel) or SPC software that requires RS-232C/virtual COM data:**

- 12AAA807** RS-232C output cable (null modem cable, can also be used to communicate with a PLC if the PLC has 9-pin RS-232C input port)
- 64AAB532** Serial to USB adapter (RS-232C cable or equivalent adapters are also needed)

**Optional accessories for sending data directly to Excel, etc. (Digimatic output, max resolution possible: 10μinch):**

- 02AGC840** Digimatic Output Card (this card is not needed if using LSM-9506)
- 06AFM380D** USB Input Tool (virtual keyboard format)

Other output options are available, including wireless. Contact us for details.

## QUICKTOOL

**Free Quicktool\*** software simplifies the setup and operation of the LSM-6200/9506/6900

This program can be downloaded from <http://www.mitutoyo.jp>

\*For use with customer-supplied PC and RS-232C cable



## BCD Interface Unit (02AGC910)

- Outputs a 7-digit BCD and a positive or negative sign.
- Switchable data logic.
- The input and output circuits are isolated.

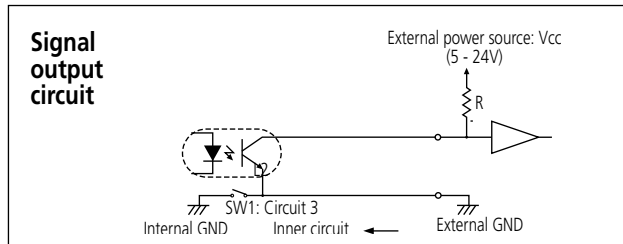
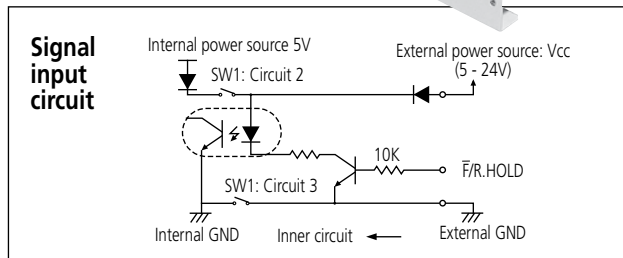
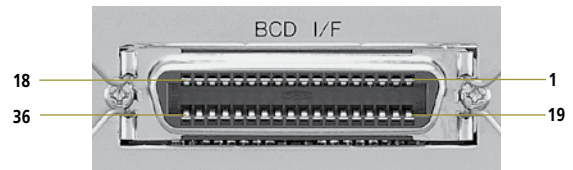
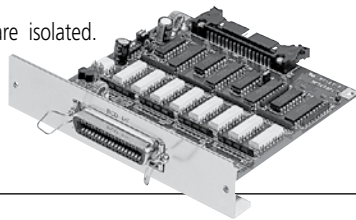

### Pin assignment of BCD Interface Unit

Pin No.	Signal name	Pin No.	Signal name	Pin No.	Signal name
1	1 x 10 <sup>0</sup>	15	4 x 10 <sup>3</sup>	29	Err:0 (Segment error)
2	2 x 10 <sup>0</sup>	16	8 x 10 <sup>3</sup>	30	HOLD (input)
3	4 x 10 <sup>0</sup>	17	1 x 10 <sup>4</sup>	31	F/R
4	8 x 10 <sup>0</sup>	18	2 x 10 <sup>4</sup>	32	STB (Strobe output)
5	1 x 10 <sup>1</sup>	19	4 x 10 <sup>4</sup>	33	EXT.Vcc (Ext. power)
6	2 x 10 <sup>1</sup>	20	8 x 10 <sup>4</sup>	34	+POLE (Polarity)
7	4 x 10 <sup>1</sup>	21	1 x 10 <sup>5</sup>	35	GND (Signal GND)
8	8 x 10 <sup>1</sup>	22	2 x 10 <sup>5</sup>	36	FG (Frame GND)
9	1 x 10 <sup>2</sup>	23	4 x 10 <sup>5</sup>		
10	2 x 10 <sup>2</sup>	24	8 x 10 <sup>5</sup>		
11	4 x 10 <sup>2</sup>	25	1 x 10 <sup>6</sup>		
12	8 x 10 <sup>2</sup>	26	2 x 10 <sup>6</sup>		
13	1 x 10 <sup>3</sup>	27	4 x 10 <sup>6</sup>		
14	2 x 10 <sup>3</sup>	28	8 x 10 <sup>6</sup>		

Applicable connector: **57-40360-D** (Standard accessory)

\*Not available for LSM-6900

### Digimatic Code-out Unit (02AGC840)

- Provides two channels of SPC (Digimatic) output.
- Outputs the following during simultaneous measurement: From OUTPUT1: Measured values by PRG.0 through PRG.4. From OUTPUT2: Measured values by PRG.5 through PRG.9
- The output cable (**936937**) is optional and is used for sending data to interfaces. **06AFM380D** can be used to send data directly to Excel, etc.



#### Signal input circuit

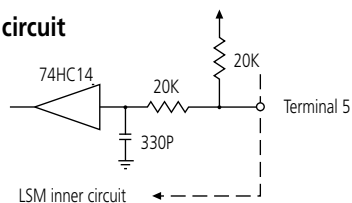

#### Signal output circuit

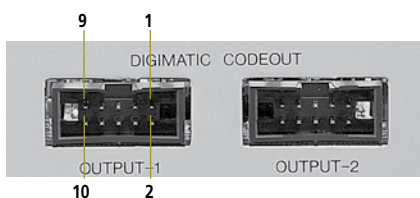
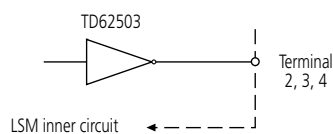

### Pin assignment of Digimatic Code-out Unit

Pin No.	Signal name	I/O	Function
1	GND	—	Signal GND
2	DATA	OUT	Data out
3	CK	OUT	Data transmission clock
4	RD	OUT	Data read request
5	REQ	IN	Data output request
6, 7, 8, 9	I.C	—	Spare
10	FG	—	Frame GND

### Dual-type Add-on Unit (02AGP150)\*

- Enables a second measuring unit to be connected to the display unit (this is possible only if the two measuring units are the same model).
- Depending on the layout of the two measuring units, large-diameter measurement, XY measurement, and parallel measurement are possible.
- The sub-display of the LSM-6200 allows simultaneous measurement and display with two measuring units.



#### Large-diameter measurement

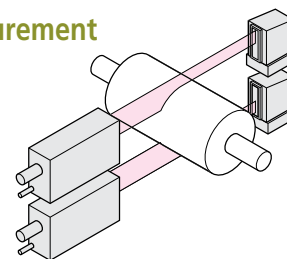

#### XY measurement

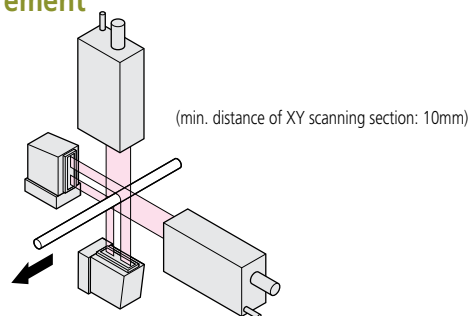

#### Parallel measurement

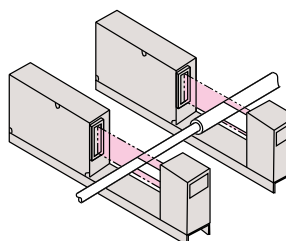

# Optional Accessories

## 2nd I/O-Analog Interface Unit (02AGC880)

- Provides I/O capability and analog voltage output for go/no-go judgment.
- Provides two sets of go/no-go judgment result outputs. Fully compatible with simultaneous measurement, since measurement values from PRG.5 through PRG.9 will be output as analog signals.

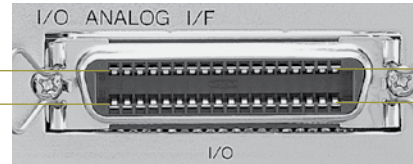
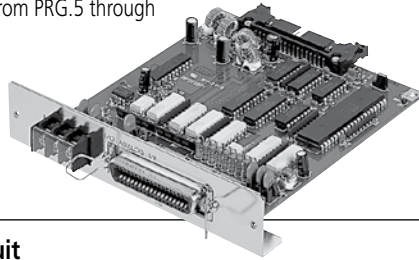

18 1  
36 19

### Pin assignment of 2nd I/O-Analog Interface Unit

#### Signal input circuit

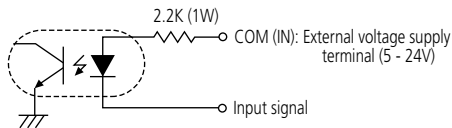

#### Signal output circuit

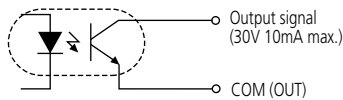

Pin No.	Signal name	I/O
1	+5V	(Internal power)
2	COM (IN)	(IN)
3	PROG.0/b0	IN
4	PROG.2/b2	IN
5	PROG.4/PRG	IN
6	SHIFT	IN
7	RUN	IN
8	A•(-NG)	OUT
9	I.C	(OUT)
10	I.C	(OUT)
11	B•(-NG)	OUT
12	B•(+NG)	OUT
13	I.C	(OUT)
14	A•(+NG)	OUT
15	A•(GO)	OUT
16	ERR.0	OUT
17	COM (OUT)	(OUT)
18	CNT	OUT
19	GND	(Internal power)
20	COM (IN)	(IN)
21	PROG.1/b1	IN
22	PROG.3/b3	IN
23	IC	(OUT)
24	PRINT	IN
25	RESET	IN
26	A•(GO)	OUT
27	I.C	(OUT)
28	I.C	(OUT)
29	B•(GO)	OUT
30	I.C	OUT
31	I.C	(OUT)
32	A•(-NG)	OUT
33	ACK	OUT
34	STB	OUT
35	COM (OUT)	(OUT)
36	FG	—

With a combined use of b0, b2, PRG, b1 and b3, maximum 100 patterns of program can be used.

## System Extension Devices

### Extension Cable for Concurrent Installation of BCD and Second I/O-Analog Interface

#### No.02AGE060

- The use of this cable enables concurrent installation of BCD (No.02AGC910) and second I/O-Analog interface (No.02AGC880) in LSM-6200/6900.

#### \*Restrictions

If this cable is used, the dual extension unit (No.02AGP150) is not available.

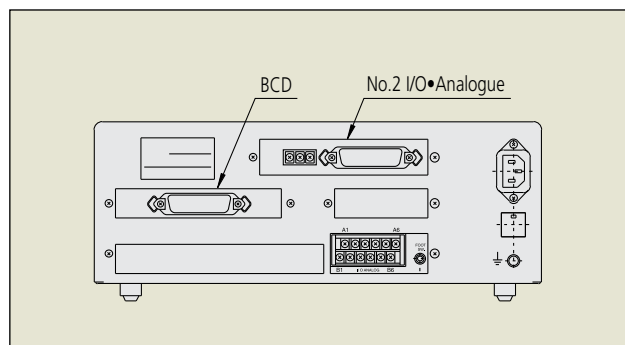
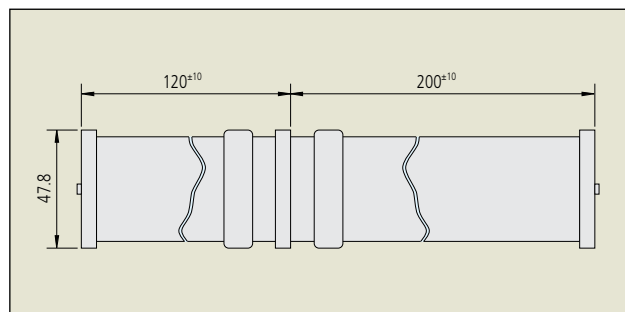

## Thermal Printer

- This printer can be connected to any LSM-5200, -6200, -6900 or -9506 model.
- Both measurement values and statistical calculation results can be printed (only with LSM-6200/6900/9506).
- Connection cable is supplied.



Order No.	02AGD600B (w/120V AC adapter)
Type	Thermal serial-dot printer
Digits per line	40
Character format	9x8 dot matrix
Data input	Via RS-232C interface
Printer life	500,000 lines
Operational temperature range	0°C to 50°C
Power supply	Via AC adapter (120V AC, 60Hz)
Standard accessories	Printer paper (1 roll), AC adapter
Consumable item	Printer paper set (10-roll, 223663)

## Footswitch (937179T)\*

- Connecting the footswitch to the LSM-6100/6900/9506 enables the user to initiate a single measurement externally.



# Glossary

## 1. Linearity

This is a specified value that defines the maximum error\* that may be indicated by the LSM after calibration\*\*, anywhere within its measuring range, when measuring a workpiece in the center of the measuring region. Note that the linearity specification does not include the calibration error specification of the calibration gages themselves. This error must be added separately.

- \* The difference between the result of measuring a dimension and the true value of the dimension measured.
- \*\* Optional calibration gages are available for each model of LSM to provide appropriate high and low calibration points (HiCAL and LoCAL on the diagram).

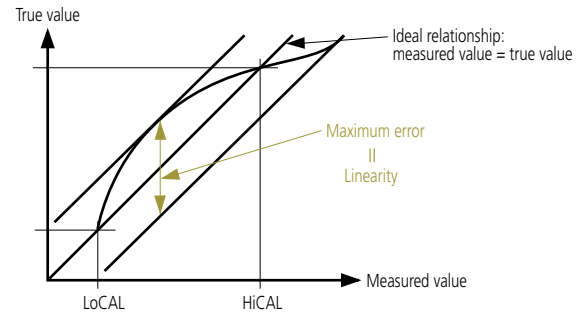

## 2. Repeatability

Means, in the center of a measuring region, the dispersion ( $\pm 2\sigma$ ) of measurement values as the result of continuous measurement for 2 minutes with the number of scans for averaging set at 512 times (1024 times for LSM-6902H/6900) without moving a workpiece of the maximum measurement diameter on each measuring unit.

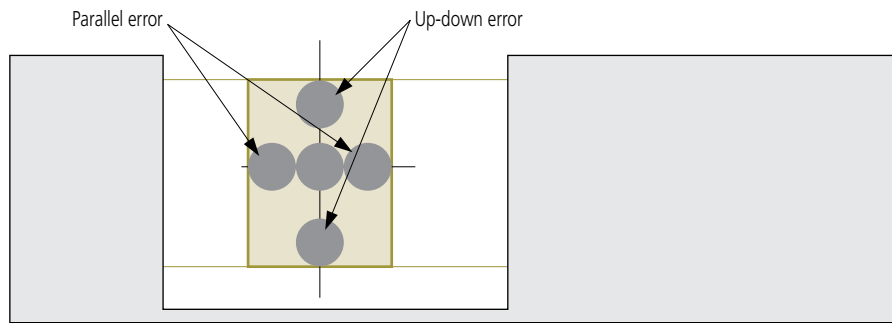

## 3. Position error

Means an error with reference to the measurement value at the center of the measuring region if a workpiece is displaced in the measuring region. A position error consists of an up-down error and a parallel error as shown in the following figure. This error separately affects measurement accuracy.

## 4. Measuring region

The LSM provides numeric values for which the accuracy (linearity + position error) is guaranteed only if a workpiece is located within the prescribed space domain. This domain is called the measuring region. A measuring region is determined by [laser beam scanning direction] x [optical axis direction]. To perform measurement with a minimum of error, it is necessary to measure a workpiece at the center of this measuring region. As an example in the figure right, workpieces 1, 2, 5, and 6 cannot be measured because these are outside the measuring region. For workpieces 3 and 4, a position error is added to a linearity error.

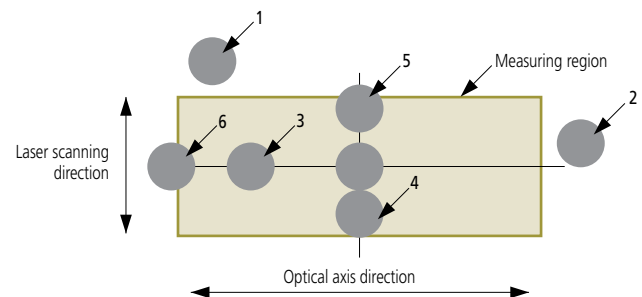

## 5. Beam diameter and width

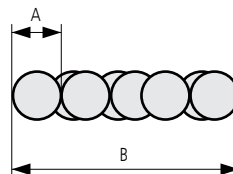

	LSM-6902H/6900	LSM-500S	LSM-501S	LSM-503S	LSM-506S	LSM-9506	LSM-512S	LSM-516S
Beam diameter A	200 $\mu$ m	80 $\mu$ m	120 $\mu$ m	240 $\mu$ m	600 $\mu$ m	600 $\mu$ m	1200 $\mu$ m	1200 $\mu$ m
Beam diameter B	300 $\mu$ m	120 $\mu$ m	170 $\mu$ m	340 $\mu$ m	800 $\mu$ m	800 $\mu$ m	1600 $\mu$ m	1600 $\mu$ m

# PRECAUTIONS

## Compatibility

Your Laser Scan Micrometer has been adjusted together with the ID unit, which is supplied with the measuring unit. The ID unit, which has the same code number and the same serial number as the measuring unit, must be installed in the display unit. This means that if the ID unit is replaced, the measuring unit can be connected to another corresponding display unit.

## The workpiece and measuring conditions

Depending on whether the laser is visible or invisible, the workpiece shape, and the surface roughness, measurement errors may result. If this is the case, perform calibration with a master workpiece which has dimensions, shape, and surface roughness similar to the actual workpiece to be measured. If measurement values show a large degree of dispersion due to the measuring conditions, increase the number of scans for averaging to improve the measurement accuracy.

## Electrical interference

To avoid operational errors, do not route the signal cable and relay cable of the Laser Scan Micrometer alongside a high-voltage line or other cable capable of inducing noise current in nearby conductors. Ground all appropriate units and cable shields.

## Connection to a computer

If the Laser Scan Micrometer is to be connected to an external personal computer via the RS-232C interface, ensure that the cable connections conform to the specification.

## Laser safety

Mitutoyo Laser Scan Micrometers use a low-power visible laser for measurement. The laser is a CLASS 2 IEC 825-1 device and a CLASS II 21 CDRH device. Warning and explanation labels, as shown right, are attached to the Laser Scan Micrometers as is appropriate.

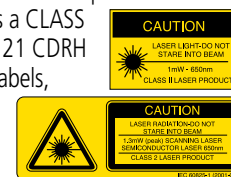

## Re-assembly after removal from the base

Observe the following limits when re-assembling the emission unit and reception unit to minimize measurement errors due to misalignment of the laser's optical axis with the reception unit.

### (1) Alignment within the horizontal plane

a. Parallel deviation between reference lines C and D: X (in the transverse direction)

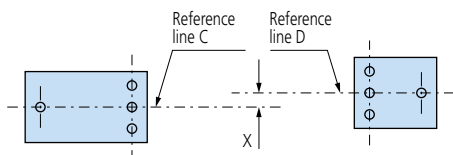

b. Angle between reference lines C and D:  $\theta_x$  (angle)

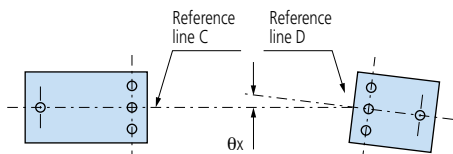

### (2) Alignment within the vertical plane

c. Parallel deviation between reference planes A and B: Y (in height)

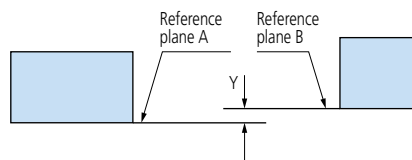

d. Angle between reference planes A and B:  $\theta_y$  (angle)

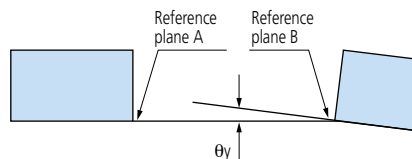

### (3) Allowable limits of optical axis misalignment

Model	Distance between Emission Unit and Reception Unit	X and Y	$\theta_x$ and $\theta_y$
LSM-501S	68mm (2.68") or less	within 0.5mm (.02")	within 0.4° (7 mrad)
	100mm (3.94") or less	within 0.5mm (.02")	within 0.3° (5.2 mrad)
LSM-503S	130mm (5.12") or less	within 1mm (.04")	within 0.4° (7 mrad)
	350mm (13.78") or less	within 1mm (.04")	within 0.16° (2.8 mrad)
LSM-506S	273mm (10.75") or less	within 1mm (.04")	within 0.2° (3.5 mrad)
	700mm (27.56") or less	within 1mm (.04")	within 0.08° (1.4 mrad)
LSM-512S	321mm (12.64") or less	within 1mm (.04")	within 0.18° (3.6 mrad)
	700mm (27.56") or less	within 1mm (.04")	within 0.08° (1.4 mrad)
LSM-516S	800mm (31.50") or less	within 1mm (.04")	within 0.09° (1.6 mrad)