

WATLOW® SERIES F4 1/4 DIN Temperature Process Controllers



High Performance Controller Offers Application Versatility and Ease of Use

The SERIES F4 1/4 DIN temperature process controller offers performance features to meet a wide range of industrial processing needs. The F4 process controller is ideal for semiconductor manufacturing equipment, plastic processing and packaging equipment and industrial process control applications.

This controller features a four line, high definition LCD interface display, in addition to an information key that enables easy setup and control operation, minimizing the chance for error. Its 16-bit microprocessor ensures accuracy and delivers performance advantages you can count on from a Watlow® controller.

Four digital inputs remotely modify controller operation or enable display of pre-defined operator messages. Advanced features include cascade, ratio, differential, duplex slide wire and retransmit options.

Serial communication and dual alarm relays are included in the base unit. The SERIES F4 is packaged with a NEMA 4X front face to withstand harsh environments and a four-inch (101.6 mm) deep case with removable connectors for wiring convenience. It is manufactured by Watlow, ISO 9001 registered and protected by a three-year warranty.

Features and Benefits

Guided setup

- Removes “guess work” from the setup process
- Saves time by reducing programming errors

High definition four-line LCD display

- Simplifies setup process and operations
- Quickly and easily identifies process, alarm and set point values

Information “I” Key

- Displays essential elements from the user manual on board

Customized menuing

- Quickly displays up to 16 parameters
- Allows users to create custom messaging and easily identify key events or alarms

High performance 16-bit microprocessor

- Provides precise process control with 20Hz update rate on Input 1 (10Hz on inputs 2 and 3)
- Calibration accuracy of $\pm 0.1\%$ of span

Universal input

- Embedded software provides application versatility
- Eliminates the need for dip switches

Modbus® communications ready

- Equipped to handle RS232 or EIA-485 communications



General Purpose Control Operation

The SERIES F4 temperature process controller with a single channel PID controller supports either closed or open loop operation. The design utilizes the latest technology to meet complex processing needs while maintaining an easily understood operator interface.

Full, non-abbreviated parameter choices are displayed using a four line, high-definition LCD interface display that is back lit for wide angle viewing. Firmware guides the operator through parameter choices for feature configuration. An information key (I) provides the operator with detailed help information regarding the parameter or feature being configured. The main page menu can be programmed to display output power through 16 control variables including: bar graphs, set points and operating ranges. Up to four programmable messages can be activated remotely to inform the operator that the process requires attention.

Five sets of PID values can be auto-tuned to support varying system reactions over the complete operating range. Up to 10 offset points can be programmed to compensate for differences between the actual process value and sensor readings caused by sensor placement.

Control Inputs

Up to three universal analog inputs are configured through software to support thermocouples, RTDs and process (voltage/current) sensors. Auxiliary inputs 2 and 3 can function as a remote set point input, sources for retransmission or as the outer loop for cascade operation.

Digital Inputs

Four inputs are programmable and can remotely modify controller operation and display pre-programmed messages on the operations display.

Control Outputs

Heat/cool or reverse/direct action is supported. Time based outputs can be configured for variable burst fire or a cycle time can be selected. On-off boost heat or boost cool operation is also supported. Boost operation is enabled based on load power requirements

Alarms

Two alarms are included in the base unit and can be programmed as process, deviation or rate.

Serial Communications

Both EIA-232 and EIA-485 communications are included in the base unit. The SERIES F4 operates via the Modbus® RTU protocol and responds to requests for information only when queried. Baud rate selections are 9600 or 19200.

Retransmit

Up to two optional programmable voltage or current signal retransmit outputs are supported. Retransmit sources include up to three process variables; set point and output percent power.

Enhanced Control Operation

An enhanced operation option for the SERIES F4 process controller includes additional universal analog inputs (inputs 2 and 3) and enhanced firmware to support several features that utilize the two additional inputs. The enhanced control option can be configured to support cascade control, (see the application diagram below), differential control, ratio control and slide wire valve control. The enhanced control option can also alternate between control inputs, display up to three process variables and support remote set point operation.

In this sample application, the SERIES F4 process controller uses the enhanced cascade control feature to heat lube oil to 51.6°C (125°F). Cascade control is a control strategy in which one control loop provides the set point for another loop. It allows the process or part temperature to be reached quickly while minimizing overshoot. Cascade is used to optimize thermal system performance with long lag times. Input 3 measures the lube oil temperature before it leaves the tank. Input 1 measures the heater temperature. The input 3 process value is compared to the set point which generates an internal set point used to control the heater.

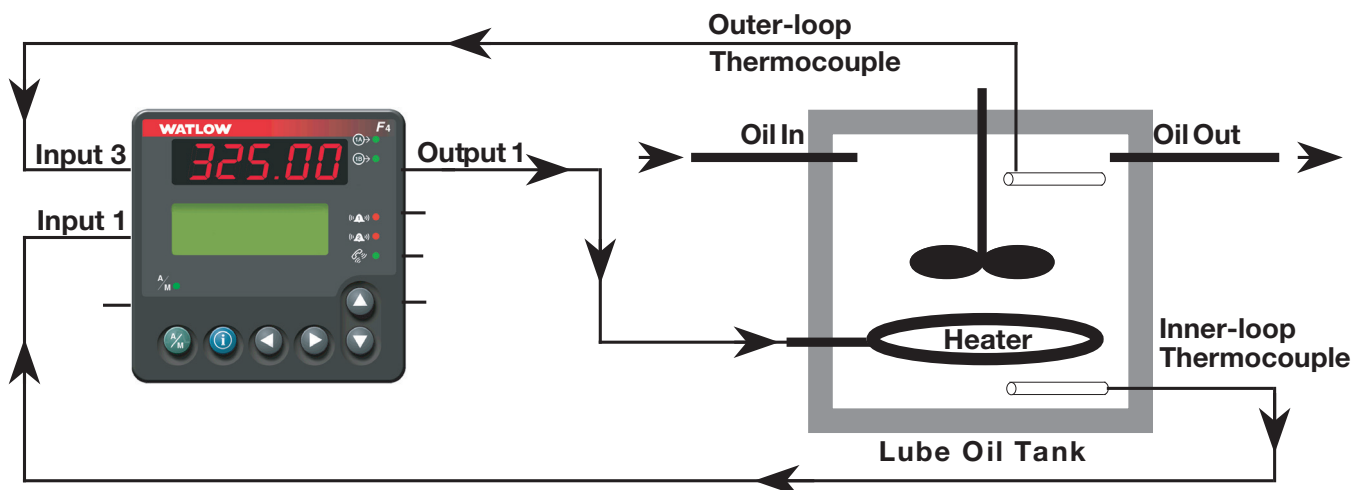

Specifications

Universal Analog Inputs 1 (2 and 3 optional)

- Update rates, IN1 = 20Hz, IN2 and IN3 = 10Hz

Thermocouple

- Type J, K, T, N, C (W5), E, Pt 2, D (W3), B, R, S

RTD

- 2- or 3-wire platinum, 100, 500, or 1K Ω
- JIS or DIN curves, 1.0 or 0.1 indication

Process

- Input resolution \approx 50,000 bits at full scale
- Range selectable: 0-10VDC, 0-5VDC, 1-5VDC, 0-50mV, 0-20mA, 4-20mA
- Voltage input impedance 20K Ω
- Current input impedance 100 Ω

Digital Inputs (4)

- Update rate = 10Hz
- Contact or dc voltage; 36VDC max
- 10K Ω input impedance

Control Outputs (1A, 1B)

- Update rate = 20Hz

Open Collector/Switched dc

- Internal load switching (nominal):
Switched dc, 22 to 28VDC, limited @ 30mA
- External load switching max.:
Open collector 42VDC @ 0.5A

Solid-state Relay

- Zero switched, optically coupled, 0.5A @ 24VAC min., 253VAC max.

Electromechanical Relay

- Form C, 2A @ 250VAC or 30VDC max.
- Resistive or inductive load
- Without contact suppression

Process Outputs (Optional Retransmit)

- Update rate = 1Hz
- User-selectable 0-10VDC, 0-5VDC, 1-5VDC @ 1K Ω min., 0-20mA, 4-20mA @ 800 Ω max.
- **Resolution:**
dc ranges = 2.5mV nominal
mA ranges = 5 μ A nominal
- **Calibration accuracy:**
dc ranges = \pm 15mV
mA ranges = \pm 30 μ A
- Temperature stability 100ppm/ $^{\circ}$ C

Alarm Outputs

- Output update rate 1Hz
- Electromechanical relay, Form C, 2A @ 30VDC or 240VAC max.

Communications

- EIA-232 and EIA-485 serial communications with Modbus[®] RTU protocol

Safety and Agency Approvals

- UL[®]/C-UL[®] 916 listed, File # E185611
Process Control Equipment
- NEMA 4X and IP65
- CE to EN 61010-1 and 61326

Terminals

- Touch-safe, removable terminal blocks, accepts 12 to 22-gauge wire

Power

- 100-240VAC, -15%, +10%; 50/60Hz, \pm 5%
- 39VA max. power consumption
- Data retention upon power failure via nonvolatile memory. Sensor input isolation from input to input to output to communication circuitry is 500VAC

Operating Environment

- 32 to 149 $^{\circ}$ F (0 to 65 $^{\circ}$ C)
- 0 to 90% RH, non-condensing
- Storage temperature: -40 to 158 $^{\circ}$ F (-40 to 70 $^{\circ}$ C)

Accuracy

- Calibration accuracy and sensor conformity: \pm 0.1% of span \pm 1 $^{\circ}$ C @ 77 $^{\circ}$ F \pm 5 $^{\circ}$ F (25 $^{\circ}$ C \pm 3 $^{\circ}$ C) ambient, and rated line voltage \pm 10% with the following exceptions:
Type T: 0.12% of span for -328 to -58 $^{\circ}$ F (-200 to -50 $^{\circ}$ C)
Types R and S: 0.15% of span for 32 to 212 $^{\circ}$ F (0 to 100 $^{\circ}$ C)
Type B: 0.24% of span for 1598 to 3092 $^{\circ}$ F (870 $^{\circ}$ C to 1700 $^{\circ}$ C)
- Accuracy span: less than or equal to operating ranges, 1000 $^{\circ}$ F (540 $^{\circ}$ C) min.
- Temperature stability: \pm 0.1 $^{\circ}$ F/ $^{\circ}$ F (\pm 0.1 $^{\circ}$ C/ $^{\circ}$ C) rise in ambient for thermocouples
- \pm 0.05 $^{\circ}$ F/ $^{\circ}$ F (\pm 0.05 $^{\circ}$ C/ $^{\circ}$ C) rise in ambient for RTD sensors

Displays

- Process: 5 digit, 7 segment LED, red
- Control interface display: 4-row, 20-character high definition LCD green

Sensor Operating Ranges

Type J:	32	to	1500 $^{\circ}$ F	or	0	to	815 $^{\circ}$ C
Type K:	-328	to	2500 $^{\circ}$ F	or	-200	to	1370 $^{\circ}$ C
Type T:	-328	to	750 $^{\circ}$ F	or	-200	to	400 $^{\circ}$ C
Type N:	32	to	2372 $^{\circ}$ F	or	0	to	1300 $^{\circ}$ C
Type E:	-328	to	1470 $^{\circ}$ F	or	-200	to	800 $^{\circ}$ C
Type C:	32	to	4200 $^{\circ}$ F	or	0	to	2315 $^{\circ}$ C
Type D:	32	to	4352 $^{\circ}$ F	or	0	to	2400 $^{\circ}$ C
Type Pt 2:	32	to	2543 $^{\circ}$ F	or	0	to	1395 $^{\circ}$ C
Type R:	32	to	3200 $^{\circ}$ F	or	0	to	1760 $^{\circ}$ C
Type S:	32	to	3200 $^{\circ}$ F	or	0	to	1760 $^{\circ}$ C
Type B:	32	to	3300 $^{\circ}$ F	or	0	to	1816 $^{\circ}$ C
RTD (DIN):	-328	to	1472 $^{\circ}$ F	or	-200	to	800 $^{\circ}$ C
RTD (JIS):	-328	to	1166 $^{\circ}$ F	or	-200	to	800 $^{\circ}$ C
Process:	-19,999 to 30,000 units						

Sensor Accuracy Ranges

Input ranges

Type J:	32	to	1382 $^{\circ}$ F	or	0	to	750 $^{\circ}$ C
Type K:	-328	to	2282 $^{\circ}$ F	or	-200	to	1250 $^{\circ}$ C
Type T:	-328	to	662 $^{\circ}$ F	or	-200	to	350 $^{\circ}$ C
Type N:	32	to	2282 $^{\circ}$ F	or	0	to	1250 $^{\circ}$ C
Type E:	-328	to	1470 $^{\circ}$ F	or	-200	to	800 $^{\circ}$ C
Type C(W5):	32	to	4200 $^{\circ}$ F	or	0	to	2315 $^{\circ}$ C
Type D(W3):	32	to	4352 $^{\circ}$ F	or	0	to	2400 $^{\circ}$ C
Type Pt 2:	32	to	2540 $^{\circ}$ F	or	0	to	1393 $^{\circ}$ C
Type R:	32	to	2642 $^{\circ}$ F	or	0	to	1450 $^{\circ}$ C
Type S:	32	to	2642 $^{\circ}$ F	or	0	to	1450 $^{\circ}$ C
Type B:	1598	to	3092 $^{\circ}$ F	or	870	to	1700 $^{\circ}$ C
RTD (DIN):	-328	to	1472 $^{\circ}$ F	or	-200	to	800 $^{\circ}$ C
RTD (JIS):	-328	to	1166 $^{\circ}$ F	or	-200	to	630 $^{\circ}$ C
Process:	-19,999 to 30,000 units						

Ordering Information

Part Number

① ② Model	③ Temperature/ Process Controller	④ Power Supply	⑤ Output 1A	⑥ Output 1B	⑦	⑧ Enhanced Control Operation	⑨ Auxiliary Retransmit Module	⑩ Language and RTD Options	⑪ ⑫ Display and Custom Options
F4	P	H	-		A	-			

③ Temperature/Process Controller	
P =	Single channel temperature/process controller, two alarms, EIA-232/485 comms. four event inputs

④ Power Supply	
H =	100-240VAC/VDC

⑤ Output 1A	
C =	Open collector/switched dc
E =	Electromechanical relay, Form C 2A without contact suppression
K =	Solid state Form A 0.5A relay without contact suppression
F =	Process, 0-5, 1-5 0-10VDC, 0-20mA, 4-20mA

⑥ Output 1B	
A =	None
E =	Electromechanical relay, Form C 2A without contact suppression
C =	Open collector/switched dc
K =	Solid state Form A 0.5A relay without contact suppression
F =	Process, 0-5, 1-5 0-10VDC, 0-20mA, 4-20mA

⑧ Enhanced Control Operation	
A =	Standard control operation
B =	Enhanced control operation, dual universal inputs, cascade, ratio, duplex, differential, slidewire

⑨ Auxiliary Retransmit Module	
0 =	None
1 =	Single retransmit output 0-5, 1-5, 0-10VDC, 0-20mA, 4-20mA
2 =	Dual retransmit output 0-5, 1-5, 0-10VDC, 0-20mA, 4-20mA

⑩ Language and RTD Option	
1 =	English with 100Ω RTD
2 =	German with 100Ω RTD
3 =	French with 100Ω RTD
4 =	Spanish with 100Ω RTD
5 =	English with 500 and 1KΩ RTD
6 =	German with 500 and 1KΩ RTD
7 =	French with 500 and 1KΩ RTD
8 =	Spanish with 500 and 1KΩ RTD

⑪ ⑫ Display and Custom Options	
RG =	Red/Green display
XX =	Custom options: software, setting parameters, overlay

Dimensional Drawings

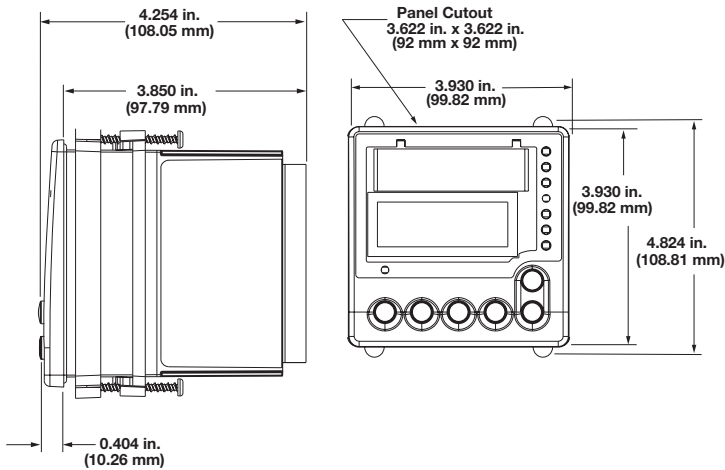

Dimension Specifications

- Width x height x depth
3.93 x 3.93 x 3.85 in. panel mount (99 x 99 x 97 mm)

Compatible Accessories

Operator Interface Terminals (OIT)



Silver Series EM touch screen operator interface terminals provide a customizable user interface, email event notifications and log and graph data for Watlow controllers and other devices. A Silver Series EM operator interface terminal paired with Watlow controllers is the perfect solution for your industrial process or machine control application.