

INSTRUCTION MANUAL

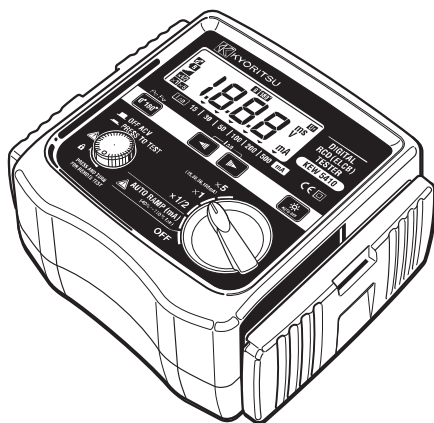

DIGITAL RCD(ELCB) TESTER

KEW 5410







**KYORITSU ELECTRICAL
INSTRUMENTS WORKS, LTD.**

Contents

1. Safety Warnings	1
2. Procedure of removing Cover	3
2-1 Method of removing the Cover	3
2-2 Method of storing the Cover	3
3. Feature.....	4
4. Specification	5
5. Instrument Layout	8
6. Measurement principle.....	10
7. Preparation	11
7-1 Connection of Test Leads	11
7-2 Setting of Measurement Range	11
7-3 Setting of $I \Delta n$	12
7-4 Setting of Test Polarity	12
7-5 Backlight	12
8. Measurements	13
8-1 Connection	13
8-2 Voltage Measurement	13
8-3 RCD Test	14
8-4 Remote Test	14
8-5 Operating time	18
9. Battery Replacement	19
10. Strap Belt Assembly	20

Symbols used on the instrument

	Primary electrical circuits of equipment connected to an AC electrical outlet by a power cord.
	Primary electrical circuits of the equipment connected directly to the distribution panel, and feeders from the distribution panel to outlets.
	Protected throughout by DOUBLE INSULATION or REINFORCED INSULATION
	User must refer to the explanations in the instruction manual.
	Earth Ground

1. Safety Warnings

This instrument has been designed, manufactured and tested according to following standards, and delivered in the best condition after passing quality control tests.

- IEC61010-1 Measurement Category CAT.III 300V / CAT.II 400V
Pollution degree 2
- IEC61010-031
- IEC61557-1, 6
- IEC60529 IP54

This instruction manual contains warnings and safety rules which have to be observed by the user to ensure safe operation of the instrument and to maintain it in safe condition. Therefore, read through these operating instructions before using the instrument.

⚠ DANGER

- Read through and understand the instructions contained in this manual before using the instrument.
 - Keep the manual at hand to enable quick reference whenever necessary.
 - The instrument is to be used only in its intended applications.
 - Understand and follow all the safety instructions contained in the manual.
- It is essential that the above instructions are adhered to. Failure to follow the above instructions may cause injury, instrument damage and/or damage to equipment under test.

- The symbol ⚠ indicated on the instrument means that the user must refer to the related parts in the manual for safe operation of the instrument. It is essential to read the instructions wherever the ⚠ symbol appears in the manual.

- ⚠ **DANGER** is reserved for conditions and actions that are likely to cause serious or fatal injury.
- ⚠ **WARNING** is reserved for conditions and actions that can cause serious or fatal injury.
- ⚠ **CAUTION** is reserved for conditions and actions that can cause injury or instrument damage.

⚠ DANGER

- This instrument is designed to measure the earth-to-line voltage 90 ~ 264V and the line-to-line voltage up to 440V (50/60Hz). Do not exceed the maximum allowable input of any measuring range.
- Do not attempt to make measurement in the presence of flammable gasses. Otherwise, the use of the instrument may cause sparking, which can lead to an explosion.
- Keep your fingers behind the safety barrier on the test leads.
- Set the Function Switch to any desirable Range before making a measurement. Do not power on the instrument with it being connected to the live circuit.
- Never attempt to use the instrument if its surface or your hand are wet.
- Never open the Battery Cover during a measurement.
- Verify proper operation on a known source before use or taking action as a result of the indication.

⚠ WARNING

- Never attempt to make any measurement if any abnormal conditions, such as a broken cover or exposed metal parts are present on the Instrument and test leads.
- Do not install substitute parts or make any modification to the instrument. Return the instrument to your local KYORITSU distributor for repair or re-calibration in case of suspected faulty operation.
- Set the Function Switch to the OFF position when removing the Battery Cover for battery replacement.
- If the overheat symbol "🔥" appears on the display, disconnect the instrument from the measuring point and allow to cool down.

⚠ CAUTION

- Firmly insert the plugs of test leads to the appropriate terminals.
- Set the Function switch to the OFF position after use, and remove the batteries if the instrument is to be stored and will not be in use for a long period.
- Use a damp cloth with neutral detergent for cleaning the instrument. Do not use abrasives or solvents.
- Do not store the instrument if it is wet.

2. Procedure of removing Cover

KEW5410 has a dedicated Cover to protect against impacts from the outside and prevent the operation part, the LCD and the Connector Block from becoming dirty. The Cover can be detached and put on the backside of the main body during measurement.

2-1 Method of removing the Cover

Slide and pull the Cover in the direction of an arrow.

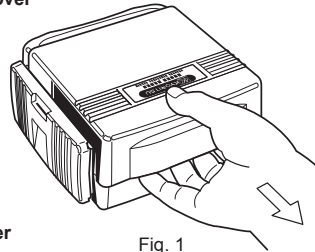

Fig. 1

2-2 Method of storing the Cover

Turn the Cover, slide and push it in the direction of arrow.

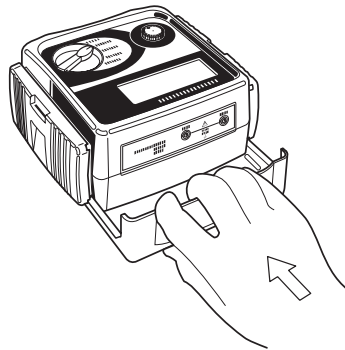

Fig. 2

3. Feature

This instrument is a digital RCD Tester to measure the trip time and trip out current of RCDs. It also equips the function to measure the voltage.

- Measurement of RCD trip time
Conducting testing of rated residual non-operating currents at x 1/2 Range, measuring RCD trip time at x1 and x5 Ranges.
- Measurement of trip out current
Measuring trip out current by varying current automatically.
- Remote Test
Enabling a user to hold the Test Leads with his both hands by locking the Test Button.
- Voltage Measurement
Carrying out a constant measurement of voltage in the stand-by mode at each Range.
- Auto-detection of Contact voltage
Detecting the voltage to earth of Earth electrodes or Protective conductors during RCD test – when applying test currents – at measurement using EARTH in order to prevent electrical shocks caused by the damaged earth.
Measurement will be ceased at AC50V (AC100V “x5 range” only) or more.
- Dust- and Water-proof
Dust- and Water-proof construction (designed to IEC60529 IP54)
- Backlight
Facilitating working at dimly illuminated locations.

4. Specification

- Measuring range and accuracy
(23°C±5°C , relative humidity 75% or less)

Range	Rated Voltage	Test current I Δ n	Measuring range	Accuracy
x 5	100V±10% 200V+32% /-10% 400V±10% 50 / 60Hz	15 / 30 / 50 / 100mA	Testing time 0ms ~ 200ms	Trip Time ±(1%rdg+3dgt)
Test Current +2% ~ +8%				
x 1		15 / 30 / 50 / 100 / 200 / 500mA	Testing time 0ms ~ 2000ms	Trip Time ±(1%rdg+3dgt)
Test Current +2% ~ +8%				
x 1 / 2	15 / 30 / 50 / 100 / 200 / 500mA	Testing time 0ms ~ 2000ms	Trip Time ±(1%rdg+3dgt)	
Test Current -8% ~ -2%				
AUTO RAMP (mA)		15 / 30 / 50 / 100 / 200 / 500mA	40%~110% of I Δ n (goes up by 5%) Testing time 300ms x 15steps	Test Current at each step -4% ~ +4%

* Only the RCD type G (without trip out time-delay) can be tested at Auto Ramp Test; type S (time-delay) cannot be tested.

Voltage Measurement

Measuring range	Accuracy
80V ~ 450V 50 / 60Hz	±(2%rdg+4dgt)

- Applied standards : IEC61010-1 Measurement Category CAT.III
300V / CAT.II 400V, Pollution degree 2
IEC61010-031
IEC61557-1, 6
IEC60529 IP54
- Display : 1999counts (3 1/2digits), Large LCD

- Used location : Altitude up to 2000m, indoor use
- Operating temperature: 0°C ~ 40°C , relative humidity 85% & humidity (no condensation)
- Storage temperature : -20°C ~ 60°C , relative humidity 85% & humidity (no condensation)
- Withstand Voltage : AC3700V / 1 min (between electrical circuit and enclosure)
- Insulation resistance : 50M Ω or more / 1000V (between electrical circuit and enclosure)
- Sleep Function : 1. Automatically enters Sleep mode in 3 min after the last switch operation (current consumption 75uA). This function doesn't work at voltage measurements. To exit from the Sleep mode, set the Function switch to OFF position once, and re-set it to the Range at which a measurement to be conducted.
2. Backlight turns off in 1 min after it lights up.
- Dimension : 186mm x 167mm x 89mm
- Weight : 965g
- Power Source : DC12V / Size AA battery R6P (SUM-3) x 8pcs
- Possible number of Measurements : 1200 times or more (measure every 30sec at x1/2 Range, $I\Delta n = 100mA$)
- Accessories : Instruction manual x 1pce
Strap belt x 1pce
Test lead M7128 x 1set (red & black cords)
Test lead with alligator clip M7129 x 1 set
Cord case x 1pce
Long pin M8017 x 2pcs
Size AA battery R6P(SUM-3) x 8pcs

● Operating error

Operating error (B) is an error obtained under the nominal operating conditions, and calculated with the intrinsic error (A), which is an error of the instrument used, and the error (En) due to variations.

$$B = \pm (| A | + 1.15 \sqrt{E_1^2 + E_2^2 + E_3^2 + E_5^2 + E_8^2})$$

- A : Intrinsic error
- E₁ : Variation due to changing the position
- E₂ : Variation due to changing the supply voltage
- E₃ : Variation due to temperature
- E₅ : Variation due to the resistance of Probe *
- E₈ : Influence by the variation in System Voltage

*Probe = auxiliary Earth electrode to be used for the sampling of electric potentials during measurements

I Δ n	Probe resistance
15mA	Less than 200 Ω
30mA	Less than 100 Ω
50/100/200/500mA	Less than 20 Ω

KEW5410 Max Operating Error (IEC61557)

Range	Max Operating Error	
x 5	test current	0% ~ +10%
	time measurement	±10%
x 1	test current	0% ~ +10%
	time measurement	±10%
x 1/2	test current	-10% ~ 0%
AUTO RAMP (mA)		±6%

5. Instrument Layout

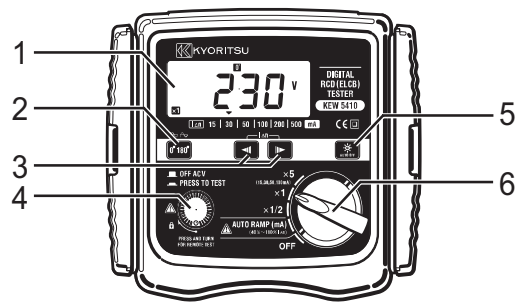

1. LCD
2. 0° / 180° Button (Polarity change)
3. I Δ n Button
4. Test Button
5. Backlight Button
6. Function Switch

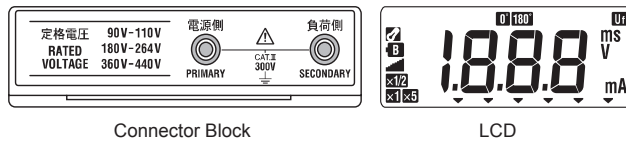
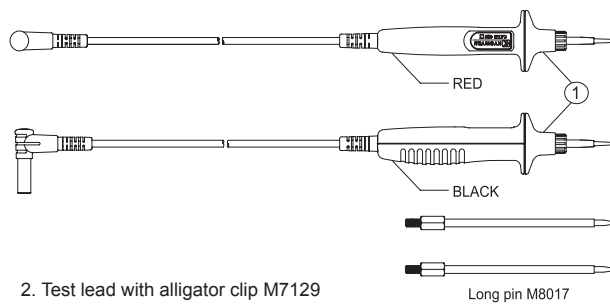

Fig. 3

Test Lead

1. Test Lead M7128



2. Test lead with alligator clip M7129

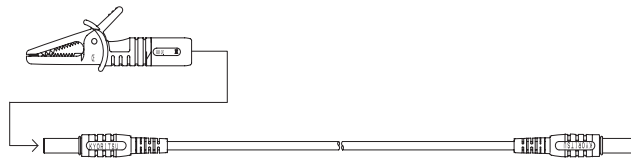

Fig. 4

* Long pin for M7128

The Tip pin of M7128 can be replaced with the Long pin M8017.

- (1) Unscrew and remove ① shown in Fig.4 and remove the Tip pin.
- (2) Install the Long pin and tighten ①.

6. Measurement principle

This instrument has a constant current circuit, and drives leakage currents (I) between LINE-NEUTRAL as illustrated in Fig.5 to activate RCDs, moreover, can output and measure leakage currents flowing to the earth as shown in Fig.6.

- Trip time measurement:
Measure and display the time between the start of driving leakage currents (I) and trip of the RCD.
- Trip out current measurement:
Increase the leakage current gradually from the 40% of $I\Delta n$, the current value when RCD trips is displayed.

Influence of the fluctuations in system voltages is less on this instrument due to the incorporated constant current circuit.

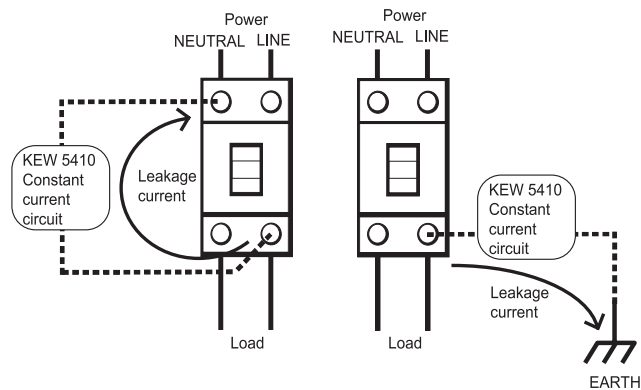

Fig. 5

Fig. 6

7. Preparation

7-1 Connection of Test Leads

Connect the test lead properly.

- Connect the test lead M7128; red cord to the load of the Connector block and black cord to the power supply.
- When using the test lead with Alligator clip, connect the test lead M7128 (red) to the load of Connector block and M7129 to the power.

7-2 Setting of Measurement Range

Turn the Function Switch and power on the instrument, then select any appropriate Ranges.

Range construction: There are 4 Ranges on this instrument.

x 5	For trip time measurement : Apply a current 5 times bigger than $I\Delta n$ to measure RCD trip time.
x 1	For trip time measurement : Apply $I\Delta n$ to measure RCD trip time.
x 1/2	For the test - rated residual non-operating current : Apply a half of $I\Delta n$ to confirm the RCD under test doesn't trip.
AUTO RAMP	For trip out current measurement : Vary a testing current in the range of 40% ~ 110% of $I\Delta n$ to measure the trip out current on the RCD.

⚠ WARNING

Do not power on the instrument with it being connected to the live circuit.

7-3 Setting of I Δ n

Balance the I Δ n of the instrument and of the RCD by using the I Δ n Button.

- Default value : 30mA
- Selectable values at x 5 Range are 15, 30, 50 and 100mA; 200 and 500mA are not available (Black arrow mark “▼” on the LCD indicates the selected value). In case that 200 or 500 mA is selected at any Ranges other than x 5 Range and set the Function Switch to x 5 Range, the value automatically restores to 30mA.

7-4 Setting of Test Polarity

Press the 0° /180° Button and select the polarity for test.

When the instrument is connected as illustrated in Fig.7, 8; current flows from the load to power in positive half cycle at 0° and flows from the load to power in negative half cycle at 180° , and when it is connected as illustrated in Fig.9; current flows from the load to earth in positive half cycle at 0° and flows from the load to earth in negative half cycle at 180° .

- Default polarity : 0°

7-5 Backlight

Press the Backlight Button and turns on the backlight to facilitate working at dimly illuminated location.

- Backlight turns off automatically in 1 min after it lights up.
Press the button again to turn it on.

8. Measurements

8-1 Connection

Connect the instrument according to Fig. 7, 8, 9.

⚠ DANGER

This instrument is designed to measure the earth-to-line voltage 90 ~ 264V and the line-to-line voltage up to 440V (50/60Hz). Do not exceed the maximum allowable input of any measuring range.

⚠ WARNING

- Power on the instrument before connecting to the measuring point.
- Prior to a measurement, confirm that the instrument isn't in the Sleep mode. If it is in the sleep mode, set the Function Switch to OFF position first and do preparation for measurement according to " Chapter 7. Preparation ".
Then connect the instrument to the measuring point.

⚠ CAUTION

Disconnect the load of the RCD to be tested before connecting the instrument. Otherwise, it may influence on the test results.

8-2 Voltage Measurement

The instrument automatically measure voltages when it detects input of voltage.

⚠ DANGER

Indication of "Lo V" is displayed on the LCD when the measured voltage is less than 80V; "Hi V" is displayed with audible warning when the measured voltage is 450V or higher. Disconnect the instrument from the measuring point immediately when "Hi V" is displayed on the LCD, and stop further measurements. The Test Button is disabled while "Lo V" or "Hi V" is displayed on the LCD, and RCD test cannot be performed.

8-3 RCD test

Press the Test Button while voltage is displayed on the LCD, then RCD test starts.

- x1/2, x1, x5 Ranges

Measured RCD trip time will be displayed on the LCD. When the RCD under test doesn't trip, "OL ms" will be displayed instead.

Test results must be matched with the operating times mentioned at clause 8.5.

- AUTO RAMP Range

Measured trip out current will be displayed on the LCD. When the RCD under test doesn't trip, "OL mA" will be displayed instead.

Measured results are kept displayed until the Function Switch, IΔn Button or 0° /180° Button is operated. Restore the tripped RCD and apply voltages; then a Voltage measurement can be re-started.

8-4 Remote Test

Connect the instrument as illustrated in Fig.7, 8, 9 with the Test Button pressed down & locked.

Then voltage measurement is conducted for about 1 sec and RCD test starts automatically.

Restore the tripped RCD with the Test Button on the instrument turned & locked, and apply voltages. Then the instrument measures voltages for about 1 sec and starts RCD test automatically again.

⚠ DANGER

- Voltage to earth of Earth electrodes or Protective conductors is automatically detected during RCD test – when applying test currents – at measurement using EARTH in order to prevent electrical shocks caused by the damaged earth. When the detected voltage at RCD test exceeding AC50V (AC100V “x5 range” only), “**U** Hi V” is displayed after pressing the Test Button and halt the measurements.

⚠ WARNING

- When overheat symbol **🔥** appears on the LCD, disconnect the instrument from the measuring point and allow to cool down.
- Replace the batteries with new ones immediately when the Low battery warning “**B**” starts flashing.
- Setting of I Δ n may not be proper or the instrument isn't connected to the object under test correctly when “no” is displayed on the LCD. The I Δ n of the instrument and the RCD under test should be the same. Check the connection prior to measurements.

⚠ CAUTION

- Measured results may be influenced by a presence of voltage between protective conductors and EARTH at measurement using protective conductors. When testing the circuit with earthed Neutral wire, check the connection between Neutral and Earth before starting measurements. Measured results may be influenced by a presence of voltage between Neutral and EARTH.
- Measured results may be influenced by a presence of leakage current in the circuit under test. Presence of leakage current may be doubt if any electric field exists in the other earth equipments.
- Resistance of earthed electrodes in the circuit under test with a Probe – auxiliary earthed electrode – should be $200\ \Omega$ (I Δ n=15mA) / $100\ \Omega$ (I Δ n=30mA) / $20\ \Omega$ (I Δ n=50/100/200/500mA), or less.
- Equipment following the RCD, e.g. capacitors or rotating mashinery, may cause a significant lengthening of the measured trip time.

- Restore the tested RCD after measurements.

● Neutral - Line

Connect the "PRIMARY" of the Connector Block to the Neutral of the power of RCD, and the "SECONDARY" of the Connector Block to the Line of the load of RCD.

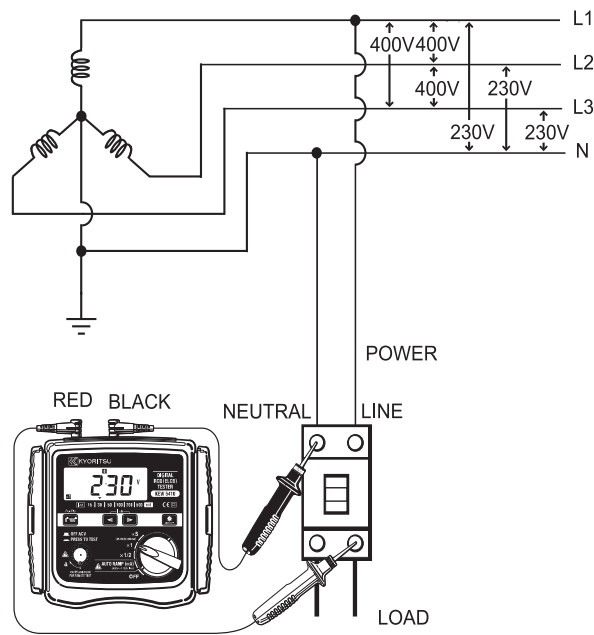

Fig. 7

⚠ DANGER

This instrument is designed to measure the earth-to-line voltage 90 ~ 264V and the line-to-line voltage up to 440V (50/60Hz). Do not exceed the maximum allowable input of any measuring range.

● Line - Line

Connect the "PRIMARY" of the Connector Block to L2 of the power of RCD, and the "SECONDARY" of the Connector Block to L1 of the load of RCD.

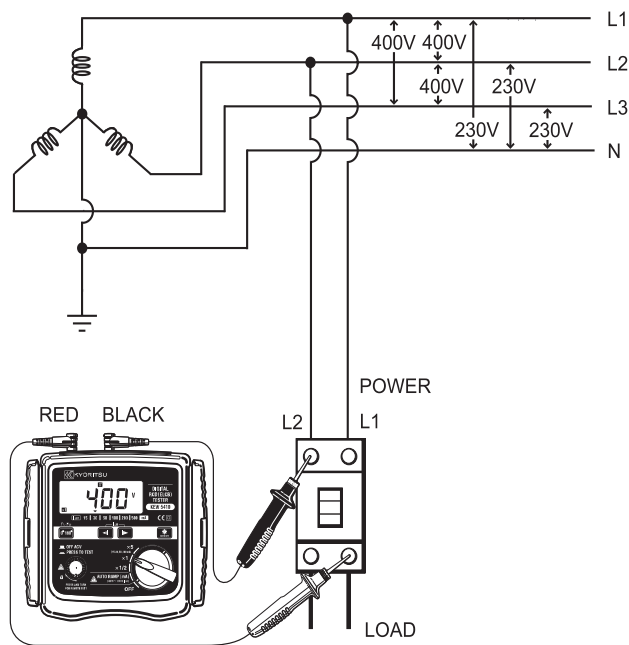

Fig. 8

⚠ DANGER

This instrument is designed to measure the earth-to-line voltage 90 ~ 264V and the line-to-line voltage up to 440V (50/60Hz). Do not exceed the maximum allowable input of any measuring range.

● Earth - Line

Connect the "PRIMARY" of the Connector Block to Earth, and the "SECONDARY" of the Connector Block to Line of the load of RCD.

Connection using Earth

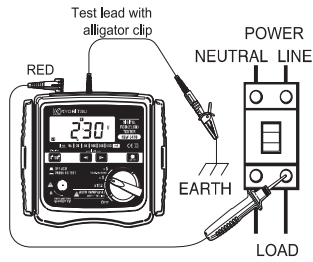
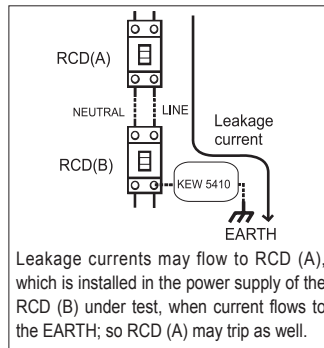

Fig. 9



Leakage currents may flow to RCD (A), which is installed in the power supply of the RCD (B) under test, when current flows to the EARTH; so RCD (A) may trip as well.

Fig. 10

⚠ DANGER

Extra caution should be taken when applying current to EARTH for tests since the other RCDs (see Fig.10) may operate and damage the devices connected to the instrument and cause accidents.

8-5 Operating time

Tripping time is the time needed by the RCD to trip at a rated residual operating current of $I\Delta n$. The standard values of tripping time are defined by IEC 61009 and IEC 61008 are listed in the table below for $I\Delta n$ and $5I\Delta n$.

Type of RCD	$I\Delta n$ (x1)	$5I\Delta n$ (x5)
General(G)	300ms	40ms
	max allowed value	max allowed value
Selective(S)	500ms	150ms
	max allowed value	max allowed value
	130ms	50ms
	min allowed value	min allowed value

9. Battery Replacement

⚠ DANGER

- Do not open the Battery Cover if the instrument is wet.
- Never replace the batteries during measurements. Set the Function switch to the OFF position and disconnect the test leads from the instrument, when replacing batteries, in order to prevent electrical shocks.

⚠ CAUTION

- Do not mix new and old batteries.
- Install batteries in the orientation as shown inside the battery compartment, observing correct polarity.

1. Set the Function switch to the OFF position, and disconnect the Test leads from the Connector Block.
2. Loosen 2 pcs of Battery Cover fixing screws, and remove the Battery Cover.
3. Replace all 8 pcs of batteries. Install new batteries observing correct polarity. Battery : R6P (size AA) x 8 pcs
4. Install the Battery Cover, and tighten up the screws.

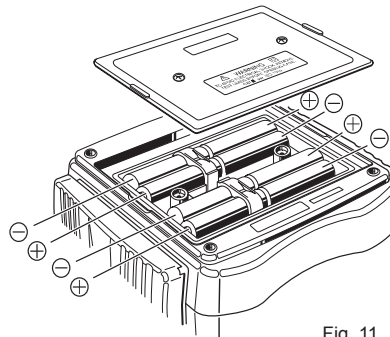

Fig. 11

10. Strap Belt Assembly

Correct assembly is shown in Fig.12. By hanging the instrument round the neck, both hand let free for testing.

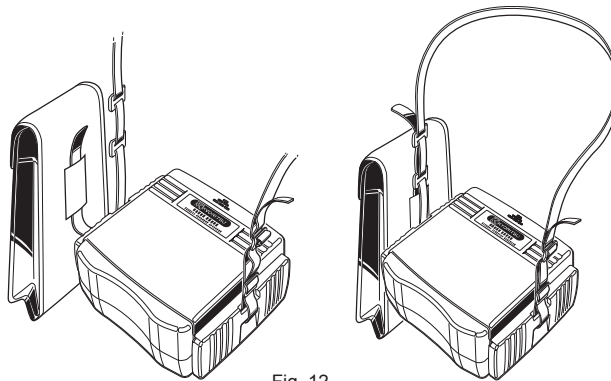

Fig. 12

Pass the Strap belt down through the side panel of the main body from the top, and up through the slots of the Probe case from the bottom.

Pass the Strap through the buckle, adjust the strap for length and secure.