

IMPORTANT:
Read Before Using

IMPORTANT :
Lire avant usage

IMPORTANTE:
Leer antes de usar



Operating/Safety Instructions
Consignes de fonctionnement/sécurité

LR20

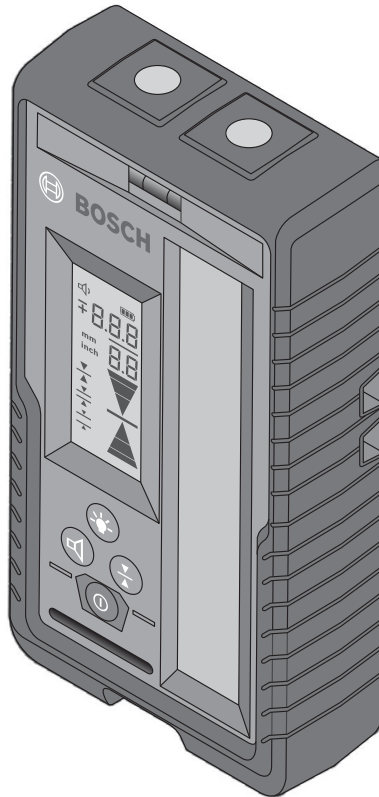

BOSCH

**Call Toll Free
for Consumer
Information &
Service Locations**

**Pour obtenir des informations
et les adresses de nos centres
de service après-vente,
appelez ce numéro gratuit**

**Llame gratis para
obtener información
para el consumidor y
ubicaciones de servicio**

**For English Version
See page 4**

LR20

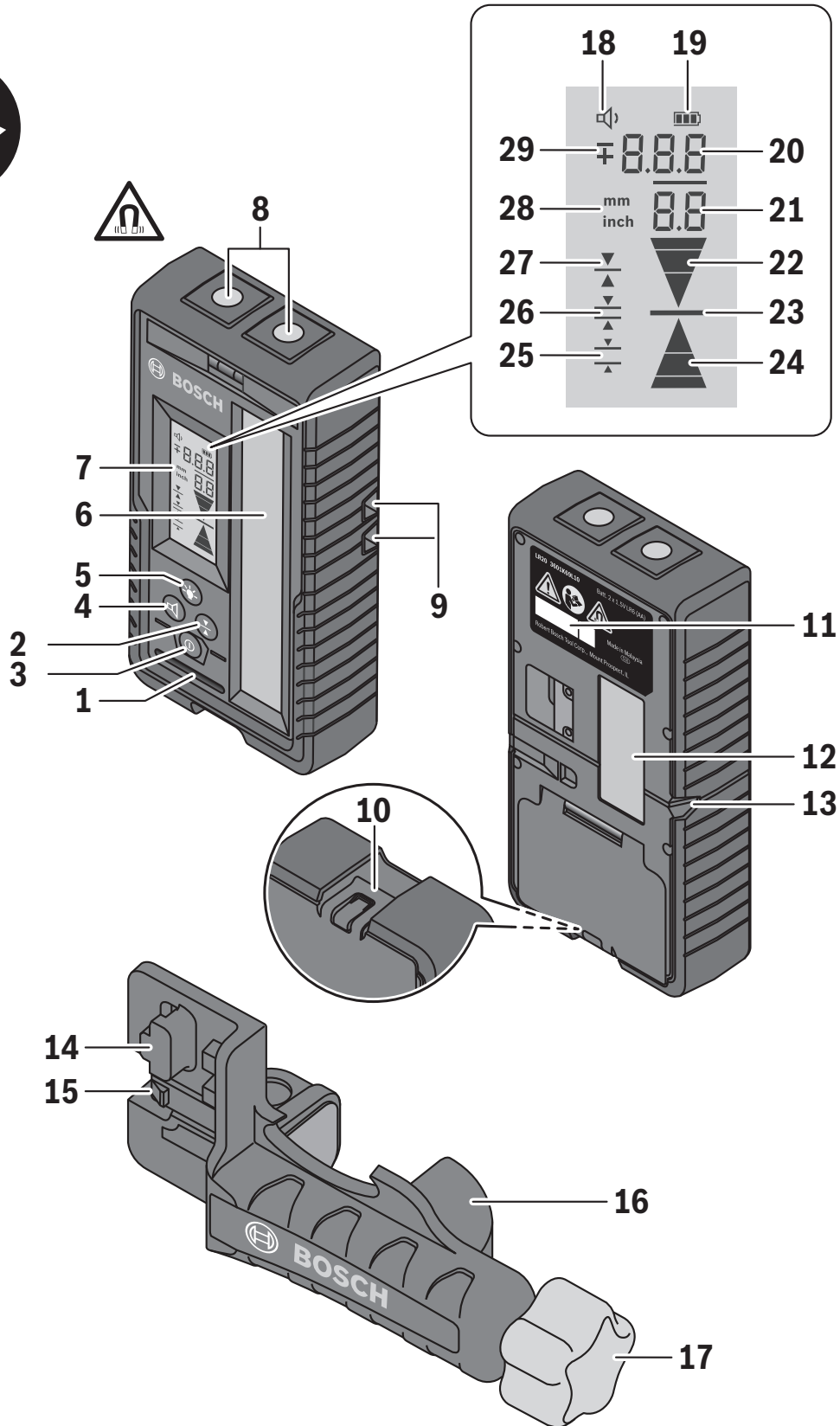

A

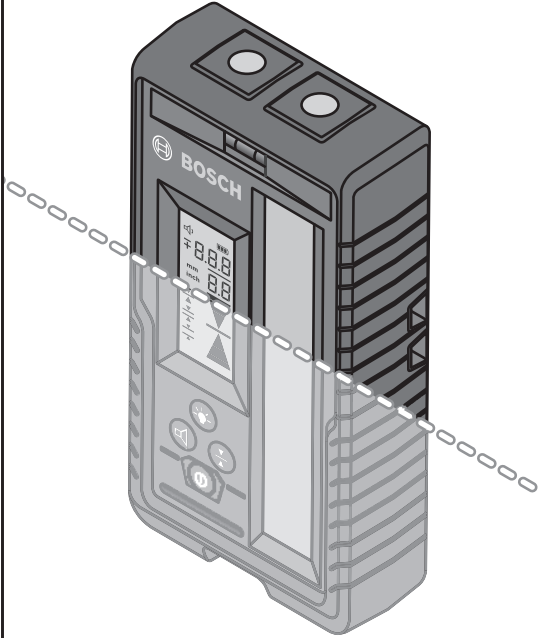
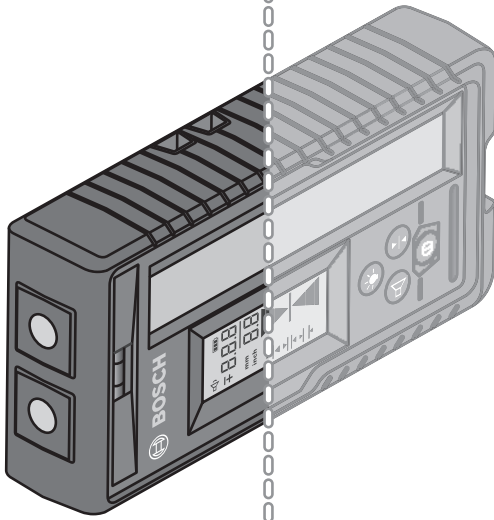

B

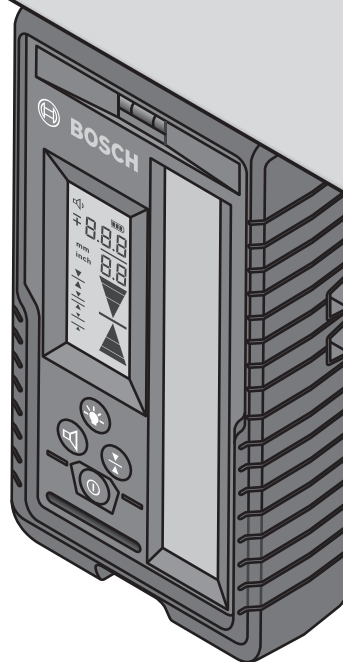

LR20 General Safety Rules



⚠ WARNING Read all instructions.

Failure to follow all instructions listed below may result in hazardous radiation exposure, electric shock, fire and/or serious injury.



Keep the laser receiver away from implants or other medical devices such as pacemaker or insulin pumps.

The magnets generate a field that can impair the function of implants or medical devices, which may lead to serious personal injury.

- **Keep the laser receiver away from magnetic data medium and magnetically sensitive equipment. The effect of the magnet plate 8 can lead to irreversible data loss.**
- **Have the laser receiver repaired only through qualified specialists using**

original spare parts. This ensures that the safety of the laser receiver is maintained.

- **Do not operate the laser receiver in explosive environments, such as in the presence of flammable liquids, gases or dusts. Sparks can be created in the laser receiver which may ignite the dust or fumes.**
- **Read and strictly observe the safety warnings in the operating instructions of the rotational laser.**

Noise Information

The A-weighted sound pressure level of the audio signal at one meter distance is 80 dB(A).

⚠ WARNING Do not hold the tool close to your ear.

LR20 Intended Use

The laser receiver is intended for swift finding of rotating laser beams in the wavelength listed in the “Technical Data”.

The laser receiver is suitable for indoor and outdoor use.

LR20 Preparation

Inserting/Replacing the Battery

Alkaline batteries are recommended for the laser receiver.

Pull the latch **10** of battery lid outward and open the battery lid.

When inserting batteries, pay attention to the correct polarity according to the representation on the inside of the battery compartment.

When the battery status **19** indicates low appears for the first time on the display **7**, the laser receiver can still be operated for approx. 1 h.

⚠ WARNING Remove the batteries from the laser receiver when not using it for extended periods. When storing for extended periods, the batteries can corrode and self-discharge.

LR20 Features

The numbering of the product features shown refers to the illustration of the measuring tool on the graphic page 2.

- 1** Speaker
- 2** Button for selecting the accuracy
- 3** On/Off button
- 4** Audio level button
- 5** Display Back-light button
- 6** Reception area for the laser beam
- 7** Front Display
- 8** Magnets
- 9** Guide groove for holder
- 10** Latch of battery lid
- 11** Serial number
- 12** Rear display
- 13** Center mark
- 14** Mounting bracket
- 15** Push-button to release the lock
- 16** Rod holder
- 17** Rotary knob of the mounting bracket

Display Elements

- 18** Audio level indicator
- 19** Battery level indicator
- 20** Offset Display Segments (mm/inch/frac.inch)
- 21** Offset Display Segments (frac.inch)
- 22** Direction indicator “move downward”
- 23** Centre indicator
- 24** Direction indicator “move upward”
- 25** Indicator for “Coarse” resolution
- 26** Indicator for “Medium” resolution
- 27** Indicator for “Fine” resolution
- 28** Inch /mm mode indicator
- 29** “+” or “-” sign for position of laser beam

LR20 Technical Data

Laser Receiver	LR20	
Article number	3601K69L10	
Receivable wavelength	635-650 nm	
Suitable for rotational laser level	GRL2000-40H, GRL2000-40HV	
Working range ¹⁾	1000 ft (300 m)	
Receiving angle	±35°	
Receiving rotation speed	150,300,600 min ⁻¹	
Accuracy ^{2) 3) 4)}		
–Setting “fine”	±1/32 in (±0.05 in)	±1 mm
	±1/16 in (±0.1 in)	±2 mm
–Setting “medium”	±1/8 in (±0.15 in)	±3 mm
	±1/4 in (±0.25 in)	±5 mm
–Setting “coarse”	±1/2 in (±0.5 in)	±7 mm
	±1 in (±1 in)	±10 mm
Operating temperature	14 °F ~ 122 °F (-10 °C ~ +50 °C)	
Storage temperature	-4 °F ~ 158 °F (-20 °C ~ +70 °C)	
Battery	2 x 1.5V LR6 (AA)	
Operating time, approx.	40h ⁵⁾	
Weight according to EPTA-Procedure 01:2014	0.661 lb (0.300 kg) without battery 0.765 lb (0.347 kg) with battery	
Dimensions	6.22 x 3.15 x 1.33 in (158 x 80 x 33.9 mm)	
Degree of protection	IP 66	

1) The working range (radius) can be reduced due to unfavorable ambient conditions (e.g. direct sunlight).

2) Depends on distance between laser receiver and rotational laser level.

3) Dependent on laser class and laser type of the rotational laser level.

4) The accuracy can be impacted by unfavorable environmental conditions (e.g. direct sun irradiation).

5) With display illumination and sound deactivated.

The laser receiver can be clearly identified with the serial number **11** on the type plate.

LR20 Operation

Initial Operation

- **Protect the laser receiver against moisture and direct sunlight.**
- **Do not subject the laser receiver to extreme temperatures or variations in temperature.** As an example do not leave it in vehicles for a long time. In case of large variations in temperature, allow the laser receiver to adjust to the ambient temperature before putting it into operation. In case of extreme temperatures or variations in temperature, the accuracy of the laser receiver can be impaired.

Setting up the Laser Receiver

Position the laser receiver at least 20 inches away from the rotational laser.

Position the laser receiver in such a manner that the laser beam can reach the reception area **6**. Align the laser receiver in such a manner that the laser beam runs laterally through the reception area (as shown on the Figure A).

Switching On and Off

- **A loud audio signal sounds when switching on the tool. Therefore, keep the tool away from your ear or other people when switching on.** The loud audio signal can cause hearing defects.

To switch the laser receiver On, press the On/Off button **3**. All display indicators light up briefly and an audio signal sounds.

Every time when the laser receiver is switched on, both volume and accuracy settings are restored from the last setting before the receiver was switched off.

To switch the laser receiver Off, press and hold On/Off button **3**. All display indicators light up briefly before the receiver switches off, and an audio signal sounds.

If no buttons on the laser receiver are pressed and no laser beam reaches the reception area **6**, for approx. 30 mins, the laser receiver switches off automatically to save energy.

Selecting the Measurement Unit

The distance between the laser beam and the center mark is shown on the display in [mm] or [in:decimals/fractions].

The default setting in delivery condition is [in: fractions].

To change the setting simultaneously press the audio level button **4** and the button **2** for selecting the accuracy until the desired setting is reached.

The selected measurement unit is saved when the laser receiver is turned off.

Selecting the Accuracy Setting

With button **2**, you can specify with which accuracy the position of the laser beam is indicated on the reception area:

- “Fine” adjustment (indication **27** on the display),
- “Medium” adjustment (indication **26** on the display).
- “Coarse” adjustment (indication **25** on the display).

Every time when the laser receiver is switched on the last accuracy setting is restored.

Direction Indicators

The position of the laser beam on the reception area **6** is indicated:

- by the direction indicators “move downward” **22**, “move upward” **24** or center **23** on the display **7** on the front of the laser receiver and display **12** at the back of the laser receiver,
- optionally by the audio signal (see “Audio Signal for Indication of the Laser Beam”)

Laser receiver too low: If the laser beam runs through the upper half of the reception area **6**, the direction indicator **24** on the display will light up and offset display segments **20/21** will also light up depending on the selected unit of measurement. If the audio signal is switched on, laser receiver shows slow beeping sound. Move the laser receiver upwards in the arrow direction.

If the laser beam is more than 30mm (1.18 inches) above the center mark of the receiver, only the direction indicator **24** on the display will light up. If the audio signal is switched on, laser receiver shows slow beeping sound.

Move the laser receiver upwards in the arrow direction. If the laser reception is interrupted due to a physical obstruction, the direction indicator **24** will flash for 3 seconds to indicate the last position of the laser beam.

Laser receiver too high: If the laser beam runs through the lower half of the reception area **6**, the direction indicator **22** on the display will light up and offset display segments **20/21** will also light up depending on the selected unit of measurement. If the audio signal is switched on, laser receiver shows fast beeping sound. Move the laser receiver downwards in the arrow direction.

If the laser beam is more than 30mm (1.18 inches) below the center mark of the receiver, only the direction indicator **22** on the display will light up. If the audio signal is switched on, laser receiver shows fast beeping sound. Move the laser receiver downwards in the arrow direction. If the laser reception is interrupted due to a physical obstruction, the direction indicator **22** will flash for 3 seconds to indicate the last position of the laser beam.

Laser receiver in center position: When the laser beam runs through the reception area **6** at the center mark **13**, the center indicator **23** on the display will light up and offset display segments **20/21** will also light up depending on the selected unit of measurement. If the audio signal is switched on, laser receiver shows continuous sound. If the laser reception is interrupted due to a physical obstruction, the center indicator **23** will flash for 3 seconds to indicate the last position of the laser beam.

Strobe Detection

If strobe light (e.g. LED lights) is present, avoid the strobe light from reaching the laser receiver.

In case of strobe light disturbance an error will be indicated by:

- flashing of the selected measurement unit
- No offset value will be displayed on the front **7** and rear display **12**.

Audio Signal for Indication of the Laser Beam

The position of the laser beam on the reception area **6** can be indicated via an audio signal.

The volume level can be adjusted or switched off.

To change the volume level or switch the audio signal off, push the acoustic signal button **4** until the desired volume level is indicated on the display. At low volume level, the audio signal indicator **18** appears on the display with no bar **18**; at high volume level, the indicator appears with one curve bar **18**. When the audio signal is set to off, the indicator goes out. Independent of the audio signal setting, a short beep sounds at low volume level each time a button is pressed on the laser receiver.

Display Back-light

The back-light of the display is switched on when the laser receiver is switched on. If no laser beam is detected and no buttons are pressed for 2 minutes, the back-light switches off automatically.

The back-light also switches off automatically if there is continuous laser detection and no buttons are pressed for 2 minutes. The back-light can be switched off manually by pressing the display back-light button **5**.

Working Advice

Marking

When the laser beam runs through the center of the reception area **6**, its height can be marked at the center mark **13** right and left of the laser receiver.

When marking, make sure to align the laser receiver both vertically and horizontally. If this is not done the laser marks will be offset from the laser beam.

Attaching with the Magnet (see figure B)

When a mounting bracket is not absolutely required, the magnets **8** on top of the laser receiver can be used to attach the receiver to steel parts.

LR20 Maintenance and Service

Keep the laser receiver clean at all times.

Do not immerse the laser receiver into water or other fluids.

Wipe off debris using a moist and soft cloth. Do not use any cleaning agents or solvents.

If the laser receiver should fail despite the care taken in manufacturing and testing procedures, repair should be carried out by an authorized after-sales service center for Bosch power tools.

In all correspondence and spare parts orders, please always include the 10-digit article number given on the type plate of the tool.

ENVIRONMENT PROTECTION



Recycle raw materials & batteries instead of disposing of waste. The unit, accessories, packaging & used batteries should be sorted for environmentally friendly recycling in accordance with the latest regulations.

LIMITED WARRANTY OF BOSCH LASER AND MEASURING TOOL PRODUCTS

Robert Bosch Tool Corporation (“Seller”) warrants to the original purchaser only, that all Bosch lasers and measuring tools will be free from defects in material or workmanship for a period of one (1) year from date of purchase. Bosch will extend warranty coverage to two (2) years when you register your product within eight (8) weeks after date of purchase. Product registration card must be complete and mailed to Bosch (postmarked within eight weeks after date of purchase), or you may register on-line at If you choose not to register your product, a one (1) year limited warranty will apply to your product.

30 Day Money Back Refund or Replacement -

If you are not completely satisfied with the performance of your laser and measuring tools, for any reason, you can return it to your Bosch dealer within 30 days of the date of purchase for a full refund or replacement. To obtain this 30-Day Refund or Replacement, your return must be accompanied by the original receipt for purchase of the laser or optical instrument product. A maximum of 2 returns per customer will be permitted.

SELLER’S SOLE OBLIGATION AND YOUR EXCLUSIVE REMEDY under this Limited Warranty and, to the extent permitted by law, any warranty or condition implied by law, shall be the repair or replacement of parts, without charge, which are defective in material or workmanship and which have not been misused, carelessly handled, or misrepaired by persons other than Seller or Authorized Service Center. To make a claim under this Limited Warranty, you must return the complete Bosch laser or measuring tool, transportation prepaid, to any BOSCH Factory Service Center or Authorized Service Center. Please include a dated proof of purchase with your tool. For locations of nearby service centers, please use our on-line service locator

THIS WARRANTY PROGRAM DOES NOT APPLY TO TRIPODS AND RODS. Robert Bosch Tool Corporation (“Seller”) warrants tripods and leveling rods for a period of one (1) year from date of purchase.

THIS LIMITED WARRANTY DOES NOT APPLY TO OTHER ACCESSORY ITEMS AND RELATED ITEMS. THESE ITEMS RECEIVE A 90 DAY LIMITED WARRANTY.

To make a claim under this Limited Warranty, you must return the complete product, transportation prepaid. For details to make a claim under this Limited Warranty

ANY IMPLIED WARRANTIES SHALL BE LIMITED IN DURATION TO ONE YEAR FROM DATE OF PURCHASE. SOME STATES IN THE U.S., AND SOME CANADIAN PROVINCES DO NOT ALLOW LIMITATIONS ON HOW LONG AN IMPLIED WARRANTY LASTS, SO THE ABOVE LIMITATION MAY NOT APPLY TO YOU.

IN NO EVENT SHALL SELLER BE LIABLE FOR ANY INCIDENTAL OR CONSEQUENTIAL DAMAGES (INCLUDING BUT NOT LIMITED TO LIABILITY FOR LOSS OF PROFITS) ARISING FROM THE SALE OR USE OF THIS PRODUCT. SOME STATES IN THE U.S., AND SOME CANADIAN PROVINCES DO NOT ALLOW THE EXCLUSION OR LIMITATION OF INCIDENTAL OR CONSEQUENTIAL DAMAGES, SO THE ABOVE LIMITATION MAY NOT APPLY TO YOU.

THIS LIMITED WARRANTY GIVES YOU SPECIFIC LEGAL RIGHTS, AND YOU MAY ALSO HAVE OTHER RIGHTS WHICH VARY FROM STATE TO STATE IN THE U.S., OR PROVINCE TO PROVINCE IN CANADA AND FROM COUNTRY TO COUNTRY.

THIS LIMITED WARRANTY APPLIES ONLY TO PRODUCTS SOLD WITHIN THE UNITED STATES OF AMERICA, CANADA AND THE COMMONWEALTH OF PUERTO RICO. FOR WARRANTY COVERAGE WITHIN OTHER COUNTRIES, CONTACT YOUR LOCAL BOSCH DEALER OR IMPORTER.

LR20 Consignes générales de sécurité



! AVERTISSEMENT

Lisez toutes les instructions. Le non-respect de toutes les instructions figurant ci-dessous risquerait de causer une exposition dangereuse aux rayonnements, un choc électrique, un incendie et/ou des blessures graves.



Ne pas mettre récepteur laser dans la proximité de stimulateurs cardiaques. Les disques magnétiques 7 génèrent un champ qui peut entraver le fonctionnement de stimulateurs cardiaques.

- Éloignez le récepteur laser des supports de données magnétiques et des équipements sensibles aux champs magnétiques. L'effet de la plaque magnétique 8 peut entraîner une perte de données irréversible.
- Faites réparer le récepteur laser uniquement par des spécialistes qualifiés utilisant des pièces de rechange d'origine. Cela garantit que la sécurité du récepteur laser est maintenue.

- N'utilisez pas le récepteur laser dans des environnements explosifs, par exemple en présence de liquides, de gaz ou de poussières inflammables. Des étincelles peuvent être créées dans le récepteur laser, ce qui peut enflammer la poussière ou les émanations.
- Lisez et observez scrupuleusement les consignes de sécurité du mode d'emploi du laser rotatif.

Informations concernant les bruits

La mesure réelle (A) du niveau de pression acoustique du signal sonore à un mètre de distance est de 85 dB(A).

! AVERTISSEMENT Ne tenez pas l'outil près de votre oreille.

LR20 Emploi prévu

Le récepteur laser est destiné à détecter rapidement les rayons laser rotatifs dans la longueur d'onde indiquée dans les "Données techniques".

Le récepteur laser est adapté à une utilisation intérieure et extérieure.

LR20 Préparation

Mise en place/changement des piles

Pour le fonctionnement de récepteur laser, nous recommandons d'utiliser des piles alcalines.

Tirez vers l'extérieur le blocage 10 du compartiment à piles et relevez le couvercle du compartiment à piles.

Faites attention à insérer les piles en respectant la polarité.

Si l'affichage des piles 19 apparaît pour la première fois sur l'écran 7, il est possible de continuer à utiliser récepteur laser pendant 2 h environ.

! AVERTISSEMENT Sortir les piles de récepteur laser au cas o l'appareil ne serait pas utilisé pour une période assez longue. En cas de stockage long, les piles peuvent corroder et se décharger.

LR20 Features

La numérotation des éléments de l'appareil se réfère à la représentation de récepteur laser sur la page 2.

- | | |
|---|---|
| 1 Haut-parleur | Éléments de l'affichage |
| 2 Bouton de sélection du degré de précision | 18 Indicateur de niveau sonore |
| 3 Bouton de marche/arrêt | 19 Indicateur du niveau de charge des piles |
| 4 Bouton de niveau sonore | 20 Segments d'affichage de la correction (mm/po/frc po) |
| 5 Bouton de rétro-éclairage de l'écran d'affichage | 21 Segments d'affichage de la correction (frac po) |
| 6 Zone de réception pour le faisceau laser | 22 Indicateur de direction / « déplacement vers le bas » |
| 7 Affichage avant | 23 Indicateur de position centrale |
| 8 Aimants | 24 Indicateur de direction / « déplacement vers le haut » |
| 9 Rainure de guidage pour le porte-outil | 25 Indicateur de résolution « Grossière » |
| 10 Verrou du couvercle du compartiment des piles | 26 Indicateur de résolution « Intermédiaire » |
| 11 Numéro de série | 27 Indicateur de résolution « Fine » |
| 12 Affichage arrière | 28 Indicateur de mode po / mm |
| 13 Marque centrale | 29 Signe « + » ou « - » pour la position du faisceau laser |
| 14 Support de montage | |
| 15 Bouton-poussoir pour ouvrir le verrou | |
| 16 Porte-tige | |
| 17 Bouton rotatif du support de montage | |